

APTRANSCO 2011 EE

Adda247

1. In a series RLC circuit at resonance, the magnitude of the voltage developed across the capacitor
 - A) Is always zero
 - B) Can never be greater than the input voltage
 - C) Can be greater than the input voltage, however, it is 90° out of phase with the input voltage
 - D) Can be greater than the input voltage, and is in phase with the input voltage

2. Two incandescent light bulbs of 40 W and 60 W rating are connected in series across the mains, then
 - A) The bulbs together consume 100 W
 - B) The bulbs together consume 50 W
 - C) The 60 W bulb glows brighter
 - D) The 40 W bulb glows brighter

3. A unit step voltage is applied at $t = 0$ to a series RL circuit with zero initial conditions
 - A) It is possible for the current to be oscillatory
 - B) The voltage across the resistor at $t = 0^+$ is zero
 - C) The energy stored in the inductor in the steady state is zero
 - D) The resistor current eventually falls to zero

4. Given two coupled inductors L_1 and L_2 their mutual inductance M satisfies
 - A) $M = \sqrt{L_1^2 + L_2^2}$
 - B) $M > \frac{(L_1 + L_2)}{2}$
 - C) $M > \sqrt{L_1 L_2}$
 - D) $M \leq \sqrt{L_1 L_2}$

5. A passive two port network is in a steady state. Compared to its input, the steady state output can never offer
 - A) Higher voltage
 - B) Lower impedance
 - C) Greater power
 - D) Better regulation

6. The minimum number of wattmeter(s) required to measure 3-phase, 3-wire balanced or unbalanced power is
 - A) 1
 - B) 2
 - C) 3
 - D) 4



ALL EXAMS, ONE SUBSCRIPTION

 **Test. Analyze. Improve. Repeat.**

 **Don't just *prepare*. *Perform*.**
Test Prime — built only for mock tests. 

 **1,50,000+**
Mock Tests

 **25,000+**
Previous Year Papers

 **800+**
Exam Covered

 **500% Refund**
on Selection

 **5 lakh+** Free Quizzes |  **Daily** Free PDFs |  **Job Alerts** Stay Updated

- Multilingual
- Detailed Solution
- Strong and Weak Areas

 **All India Rankings**
Compete with lakhs. Rank. Improve. Repeat. 

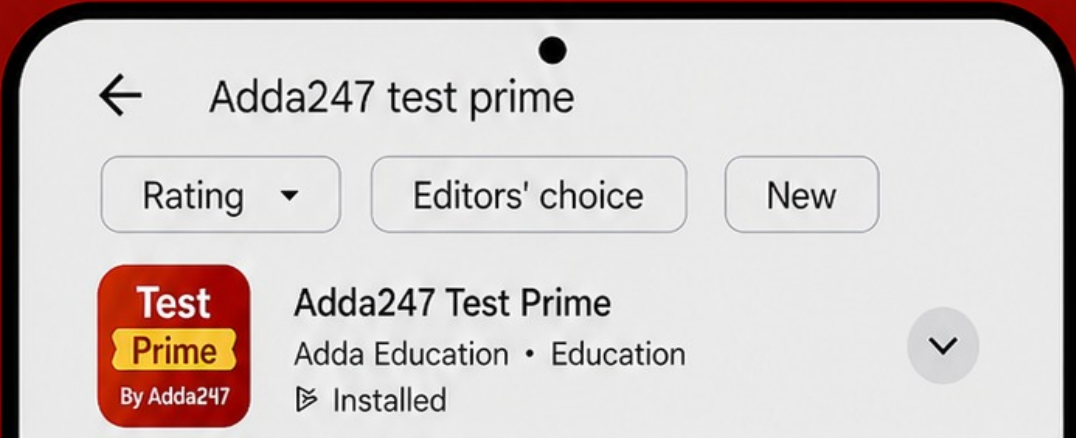

»»» DOWNLOAD THE APP «««

7. Consider the star network shown in figure. The resistance between terminals A and B with C open is 6 ohms, between terminals B and C with A open is 11 ohms and between terminals C and A with B open is 9 ohms. Then R_A, R_B, R_C respectively is

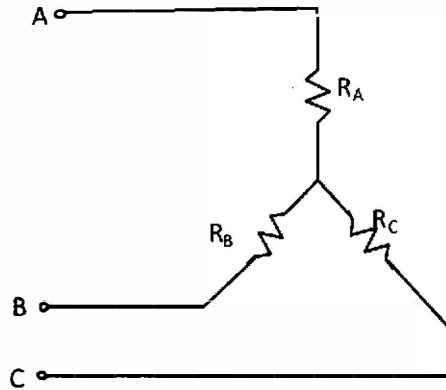

- A) 4, 2, 5 B) 2, 4, 7 C) 3, 3, 4 D) 5, 1, 10
8. A voltage wave form $v(t) = 12t^2$ is applied across a 1H inductor for $t \geq 0$. With initial current through it being zero. The current through the inductor for $t \geq 0$ is given by
 A) $12t$ B) $24t$ C) $12t^3$ D) $4t^3$
9. A two port device is defined by the following pair of equations: $i_1 = 2v_1 + v_2$ and $i_2 = v_1 + v_2$. Its impedance parameters ($z_{11}, z_{12}, z_{21}, z_{22}$) are given by
 A) (2, 1, 1, 1) B) (1, -1, -1, 2)
 C) (1, 1, 1, 2) D) (2, -1, -1, 1)
10. The period of the signal $x(t) = 8 \sin(0.8\pi t + \frac{\pi}{4})$ is
 A) 0.4π s B) 0.8π s C) 1.25 s D) 2.5 s
11. The switch in the circuit has been closed for a long time. It is opened at $t = 0$. At $t = 0^+$, the current through the 1 micro farad capacitor is

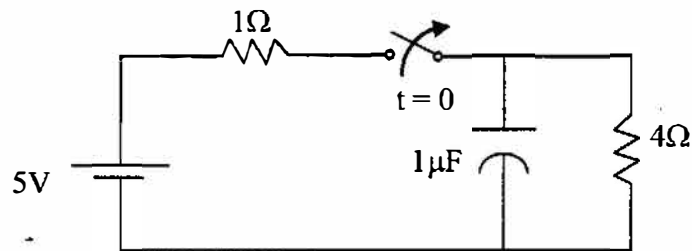

- A) 0A B) 1A C) 1.25A D) 5A

12. As shown in the figure, 1 ohm resistance is connected across a source that has a load line $v + i = 100$. The current through the resistance is

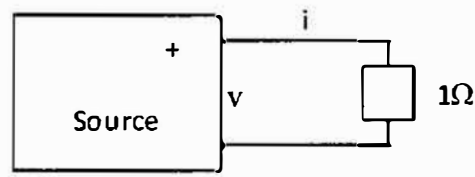

- A) 25 A B) 50 A C) 100 A D) 200A

13. The number of chords in the graph of the given circuit will be

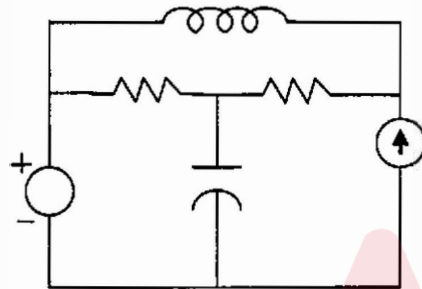

- A) 3 B) 4 C) 5 D) 6

14. The time constant for the given circuit is

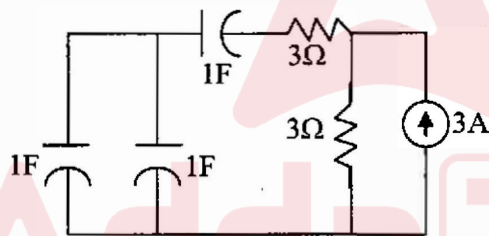

- A) $\frac{1}{9}$ S B) $\frac{1}{4}$ S C) 4S D) 9S

15. Assuming ideal elements in the circuit shown, the voltage v_{ab} will be

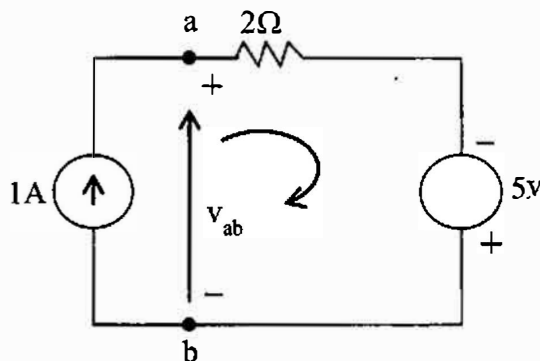

- A) -3V B) 0V C) 3V D) 5V

16. The core flux of a practical transformer with a resistive load
- A) Is strictly constant with load changes
 - B) Increases linearly with load
 - C) Increases as the square root of the load
 - D) Decrease with increased load
17. The phase sequence of a three phase alternator will reverse, if
- A) The field current is reversed keeping the direction of rotation same
 - B) The field current remains the same but the direction of rotation is reversed
 - C) The field current is reversed and the number of poles is doubled
 - D) The number of poles is doubled without reversing the field current
18. The function of oil in a transformer is to provide
- A) Insulation and cooling
 - B) Protection against lightning
 - C) Protection against short circuit
 - D) Lubrication
19. A cylindrical rotor synchronous motor is switched on to the supply with its field windings shorted on themselves, the motor will
- A) Not start
 - B) Start but will not run at synchronous speed
 - C) Start as an induction motor and then run as a synchronous motor
 - D) Start and run as a synchronous motor
20. A 4-pole lap-wound DC generator has a developed power of P watts and brush voltage of E volts. Two adjacent brushes of the machine are removed as they are worn out. If the machine operates with the remaining brushes, the developed voltage and power that can be obtained from the machine are:
- A) E, P
 - B) $\frac{E}{2}$, $\frac{P}{2}$
 - C) $\frac{E}{4}$, $\frac{P}{4}$
 - D) $\frac{E}{2}$, $\frac{P}{2}$
21. Starting torque can be obtained in the case of a single phase induction motor with identical main and auxiliary windings by connecting
- A) A capacitor across the mains
 - B) A capacitor in series with the machine
 - C) A capacitor in series with the auxiliary winding
 - D) The main and auxiliary winding in series
22. A 400V/100 V, 10 KVA two-winding transformer is reconnected as an auto-transformer across a suitable voltage source. The maximum rating of such an arrangement could be
- A) 50 KVA
 - B) 15 KVA
 - C) 12.5 KVA
 - D) 8.75 KVA

23. If an induction machine is run at above synchronous speed, it
- A) Acts as a synchronous motor
 - B) Acts as an induction generator
 - C) Acts as an induction motor
 - D) Would get damaged
24. The low voltage winding of a 400/230 V, 1-phase, 50 Hz transformer is to be connected to a 25 Hz supply. In order to keep the magnetization current at the same level as that for normal 50 Hz supply, at 25 Hz the supply voltage should be
- A) 230 V B) 115 V C) 460 V D) 65 V
25. A single-phase transformer has a turns ratio of 1:2 and is connected to a purely resistive load as shown in the figure. The magnetizing current drawn is 1A, and the secondary current is 1A. If core losses and leakage reactances are neglected, the primary current is

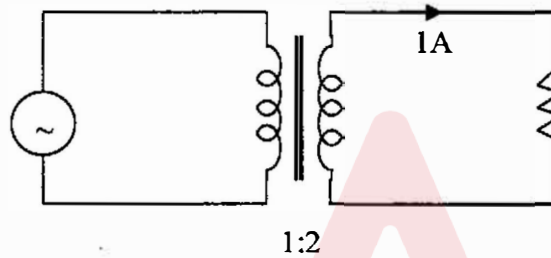

- A) 1.41A B) 2 A C) 2.24 A D) 3 A
26. A separately excited d.c. machine is coupled to a 50 Hz, three-phase, 4-pole induction machine as shown in the figure. The dc machine is energized first and the machines rotate at 1600 rpm. Subsequently the induction machine is also connected to a 50 Hz, three phase source, the phase sequence being consistent with the direction of rotation. In steady state

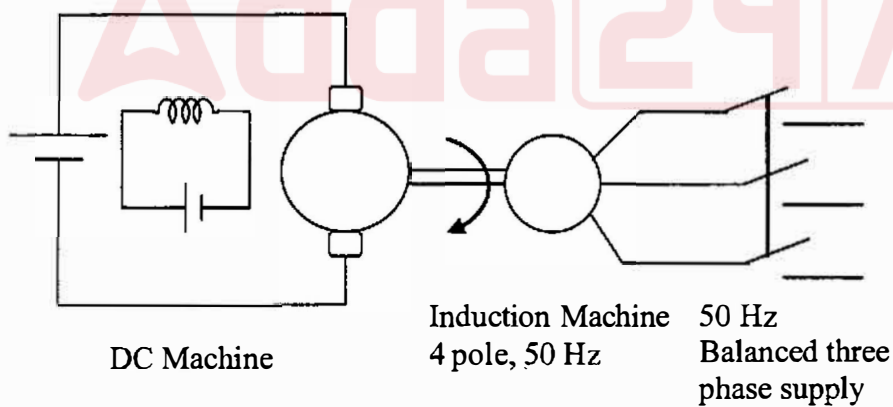

- A) Both machines act as generators
- B) DC machine acts as generator and induction machine acts as motor
- C) DC machine acts as a motor and the induction machine acts as a generator
- D) Both machines act as motors

27. A 4-point starter is used to start and control the speed of a
- A) DC shunt motor with armature resistance control
 - B) DC shunt motor with field weakening control
 - C) DC series motor
 - D) Thyristor controlled d.c. motor
28. In a transformer, zero voltage regulation at full load is
- A) Not possible
 - B) Possible at unity power factor load
 - C) Possible at leading power factor load
 - D) Possible at lagging power factor load
29. In transformers, which of the following statements is valid?
- A) In an open circuit test, copper losses are obtained while in short circuit test, core losses are obtained
 - B) In an open circuit test, current is drawn at high power factor
 - C) In a short circuit test, current is drawn at zero power factor
 - D) In an open circuit test, current is drawn at low power factor
30. For a single phase capacitor start induction motor, which of the following statements is valid?
- A) The capacitor is used for power factor improvement
 - B) The direction of rotation can be changed by reversing the main winding terminals
 - C) The direction of rotation cannot be changed
 - D) The direction of rotation can be changed by interchanging the supply terminals
31. During hunting of synchronous motor
- A) Negative phase sequence currents are generated
 - B) Harmonics are developed in the armature current
 - C) Damper bars develop torque
 - D) Field excitation increases
32. When the supply voltage to an induction motor is reduced by 10%, the maximum torque will decrease by about
- A) 5%
 - B) 10%
 - C) 20%
 - D) 40%
33. An induction motor having full load torque of 60 Nm when delta connected develops a starting torque of 120 Nm. For the same supply voltage if the motor is changed to star connection, the starting torque developed will be
- A) 40 Nm
 - B) 60 Nm
 - C) 90 Nm
 - D) 120 Nm

43. If the reference bus is changed in two load flow runs with same system data and power obtained for reference bus taken as specified P and Q in the latter run, the system losses
- A) Will be unchanged but complex bus voltages will change
 - B) Will change but complex bus voltage remain unchanged
 - C) As well as complex bus voltage will be changed
 - D) As well as complex bus voltage will be unchanged
44. Resistance switching is employed in
- A) All breakers
 - B) Bulk oil breakers
 - C) Minimum oil breakers
 - D) Air blast circuit breakers
45. Which material is used in controlling chain reaction in a nuclear reactor?
- A) Thorium
 - B) Uranium
 - C) Boron
 - D) Beryllium
46. The concept of an electrically short, medium and long line is primarily based on the
- A) Nominal voltage of the line
 - B) Physical length of the line
 - C) Wave length of the line
 - D) Power transmitted over the line
47. In a biased differential relay, the bias is defined as the ratio of
- A) Number of turns of restraining coil and operating coil
 - B) Operating coil current and restraining coil current
 - C) Fault current and operating coil current
 - D) Fault current and restraining coil current
48. Out of the following plant categories
i) Nuclear ii) Run-off-river iii) Pump storage iv) Diesel
the base load power plants are
- A) (i) and (ii)
 - B) (ii) and (iii)
 - C) (i), (ii) and (iv)
 - D) (i), (ii) and (iii)
49. For a fixed value of complex power flow in a transmission line having a sending end voltage V , the real power loss will be proportional to
- A) V
 - B) V^2
 - C) $1/V^2$
 - D) $1/V$

50. Power is transferred from system A to system B by a HVDC link as shown in the figure. If the voltage V_{AB} and V_{CD} are as indicated in the figure, and $I > 0$, then

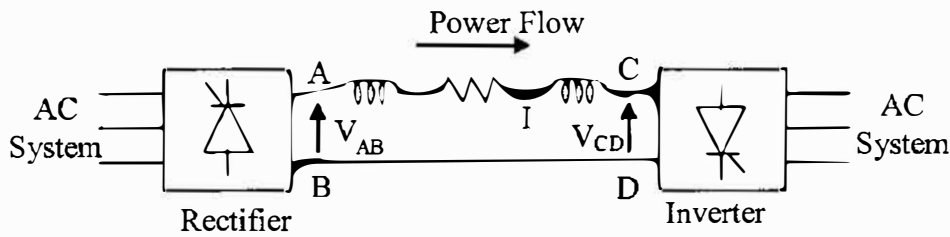

- A) $V_{AB} < 0, V_{CD} < 0, V_{AB} > V_{CD}$
 B) $V_{AB} > 0, V_{CD} > 0, V_{AB} < V_{CD}$
 C) $V_{AB} > 0, V_{CD} > 0, V_{AB} > V_{CD}$
 D) $V_{AB} > 0, V_{CD} < 0$
51. Consider two buses connected by an impedance of $(0 + j5)$ ohms. The bus 1 voltage is $100\angle 30^\circ$ V and bus 2 voltage is $100\angle 0^\circ$ V. The real and reactive power supplied by bus 1, respectively are
- A) 1000W, 268 VAR B) -1000W, -134VAR
 C) 276.9W, -56.7 VAR D) -276.9W, -56.7 Var
52. Keeping in view the cost and overall effectiveness, the following circuit breaker is best suited for capacitor bank switching.
- A) Vacuum B) Air blast C) SF_6 D) Oil
53. The Gauss seidel load flow method has the following disadvantages. Tick the incorrect statement.
- A) Unreliable convergence
 B) Slow convergence
 C) Choice of slack bus affects convergence
 D) A good initial guess for voltages is essential for convergence
54. The rated voltage of a 3-phase power system is given as
- A) rms phase voltage
 B) Peak phase voltage
 C) rms line to line voltage
 D) Peak line to line voltage
55. For induction heating, which of the following is abnormally high?
- A) Voltage B) Current C) Frequency D) Phase angle
56. Electric welding equipment works best at
- A) Low voltage and low current
 B) Low voltage and high current
 C) High voltage and low current
 D) High voltage and high current

57. Introduction of integral action in the forward path of a unity feedback system results in a
- A) Marginally stable system
 - B) System with no steady state error
 - C) System with increased stability margin
 - D) System with better speed of response

58. The closed-loop transfer function of a control system is given by

$$\frac{C(S)}{R(S)} = \frac{1}{1+S}$$

For the input $r(t) = \sin t$, the steady value of $C(t)$ is equal to

- A) $\frac{1}{\sqrt{2}} \cos t$
- B) 1
- C) $\frac{1}{\sqrt{2}} \sin t$
- D) $\frac{1}{\sqrt{2}} \sin\left(t - \frac{\pi}{4}\right)$

59. Dielectric heating is used for heating

- A) Wood
- B) Aluminium
- C) Magnetic steel
- D) Copper

60. Tractive effort acts

- A) At 90° with respect to the rails measured in counter clockwise direction
- B) At 270° with respect to the rails measured in counter clockwise direction
- C) Tangential to the driving wheel
- D) For overcoming the effect of gravity only when a train is being hauled

61. The impulse response of an initially relaxed linear system is $e^{-2t}u(t)$. To produce a response of $te^{-2t}u(t)$, the input must be equal to

- A) $2e^{-t}u(t)$
- B) $\frac{1}{2}e^{-2t}u(t)$
- C) $e^{-2t}u(t)$
- D) $e^{-t}u(t)$

62. The characteristic equation of a feedback control system is $2S^4 + S^3 + 3S^2 + 5S + 10 = 0$

The number of roots in the right half of s-plane is

- A) Zero
- B) 1
- C) 2
- D) 3

63. Phase lead compensation is used to

| | Increase | Decrease |
|----|------------------------|------------------------|
| A) | Rise time | Over shoot |
| B) | --- | Rise time & over shoot |
| C) | Rise time & over shoot | --- |
| D) | Overshoot | Rise time |

64. For a feedback control system of type 2, the steady error for a ramp input is
 A) Infinite B) Constant C) Zero D) Indeterminate
65. The output of a linear time invariant control system is $c(t)$ for a certain input $r(t)$. If $r(t)$ is modified by passing it through a block whose transfer function is e^{-s} and then applied to the system, the modified output of the system would be
 A) $\frac{c(t)}{1+e^t}$ B) $\frac{c(t)}{1-e^{-t}}$ C) $c(t-1)u(t-1)$ D) $c(t)u(t-1)$
66. The pressure coil of a dynamometer type wattmeter is
 A) Highly inductive B) Highly resistive
 C) Purely resistive D) Purely inductive
67. The two inputs of a CRO are fed with two stationary periodic signals. In the X-Y mode, the screen shows a figure which changes from ellipse to circle and back to ellipse with its major axis changing orientation slowly and repeatedly. The following inference can be made from this
 A) The signals are not sinusoidal
 B) The amplitudes of the signals are very close but not equal
 C) The signals are sinusoidal with their frequencies very close but not equal
 D) There is a constant but small phase difference between the signals
68. A wattmeter is connected as shown in the figure. The wattmeter reads

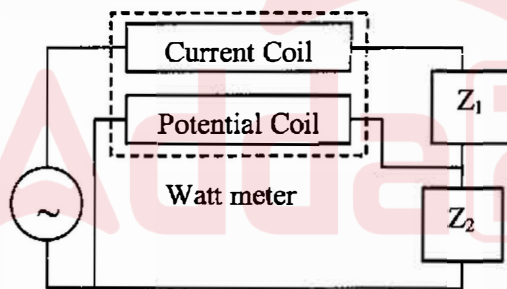

- A) Zero always B) Total power consumed by Z_1 and Z_2
 C) Power consumed by Z_1 D) Power consumed by Z_2
69. An ammeter has a current range of 0-5A and its internal resistance is 0.2 ohm. In order to change the range to 0-25 A, we need to add a resistance of
 A) 0.8 ohm in series with the meter
 B) 1.0 ohm in series with the meter
 C) 0.04 ohm in parallel with the meter
 D) 0.05 ohm in parallel with the meter

70. Consider the following statements
- i) The compensating coil of a low power factor wattmeter compensates the effect of the impedance of the current coil
 - ii) The compensating coil of a low power factor wattmeter compensates the effect of the impedance of the voltage coil circuit
- A) (i) is true but (ii) is false B) (i) is false but (ii) is true
C) Both (i) and (ii) are true D) Both (i) and (ii) are false

71. The time/div and voltage/div axes of an oscilloscope have been erased. When a 1 kHz, 5V p-p square wave calibration pulse is connected to channel 1 of the scope the waveform observed on the screen is as shown in the upper trace of the figure. An unknown signal is connected to channel 2 (lower trace) of the scope. If the time/div and V/div on both channels are the same, the amplitude (p-p) and period of the unknown signal are respectively.

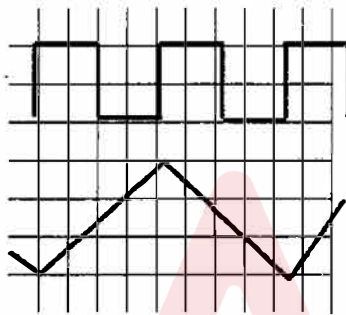

- A) 5V, 1ms B) 5V, 2ms C) 7.5 V, 2ms D) 10 V, 1 ms
72. A current of $-8+6\sqrt{2}(\sin\omega t+30^\circ)$ A is passed through three meters. They are a centre zero PMMC meter, a true rms meter and a moving iron instrument. The respective readings in A will be
- A) 8, 6, 10 B) 8, 6, 8 C) -8, 10, 10 D) -8, 2, 2
73. R_1 and R_4 are the opposite arms of a Wheatstone bridge as are R_3 and R_2 . The source voltage is applied across R_1 and R_3 . Under balanced conditions which one of the following is true
- A) $R_1 = \frac{R_3 R_4}{R_2}$ B) $R_1 = \frac{R_2 R_3}{R_4}$
C) $R_1 = \frac{R_2 R_4}{R_3}$ D) $R_1 = R_2 + R_3 + R_4$
74. A d.c. potentiometer is designed to measure up to about 2V with a slide wire of 800 mm. A standard cell of emf 1.18V obtains balance at 600 mm. A test cell is seen to obtain balance at 680 mm. The emf of the test cell is
- A) 1.00 V B) 1.34 V C) 1.50 V D) 1.70 V

75. The effect of stray magnetic fields on the actuating torque of a portable instrument is maximum when the operating field of the instrument and the stray fields are
 A) Perpendicular B) Parallel
 C) Inclined at 60° D) Inclined at 30°
76. A reading of 120 is obtained when a standard inductor was connected in the circuit of a Q-meter and the variable capacitor is adjusted to a value of 300 pF. A lossless capacitor of unknown value C_x is then connected in parallel with the variable capacitor and the same reading was obtained when the variable capacitor is readjusted to a value of 200 pF. The value of C_x in pF is
 A) 100 B) 200 C) 300 D) 500
77. A voltage signal $10 \sin \omega t$ is applied to the circuit with ideal diodes, as shown in figure. The maximum and minimum values of the output waveform v_{out} of the circuit are respectively

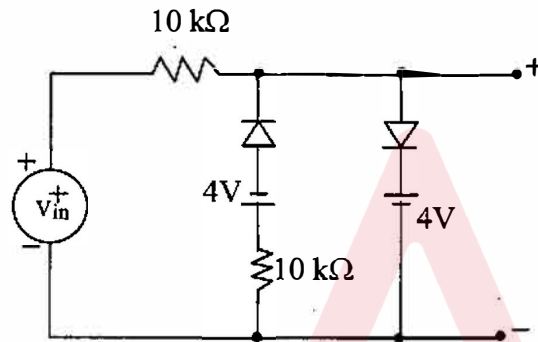

- A) +10 V and -10V B) +4V and -4 V
 C) +7 V and -4 V D) +4 V and -7 V
78. The Boolem expression $x'yz' + x'y'z + xyz' + xyz + xy'z$ can be simplified to
 A) $xz' + x'z + yz$ B) $xz + y'z + yz'$
 C) $x'y + yz + xz$ D) $x'y' + yz' + x'z$

The frequency of the clock signal applied to the rising edge triggered D flip-flop shown in figure is 10 KHz. The frequency of the signal at Q is

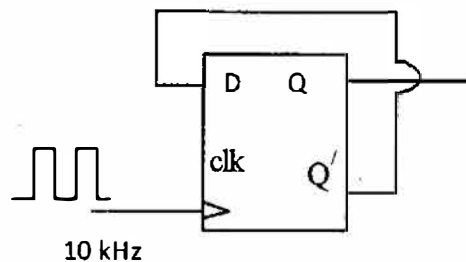

- A) 10 KHz B) 2.5 KHz C) 20 KHz D) 5 KHz

80. The output voltage V_o of the Schmitt trigger shown in figure swings between +15V and -15V. Assume that the operational amplifier is ideal. The output will change from +15 V to -15V when the instantaneous value of the input sine wave is

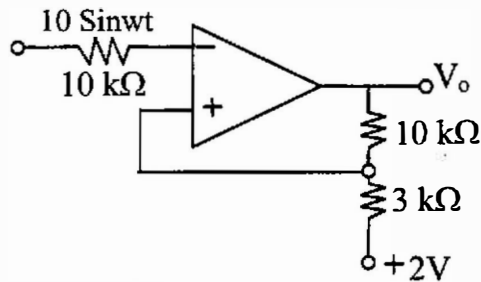

- A) 5 V in the positive slope only
 B) 5 V in the negative slope only
 C) V in the positive and negative slopes
 D) 3 V in the positive and negative slopes
81. For the circuit shown in figure, the Boolean expression for the output y in terms of inputs P, Q, R and S is

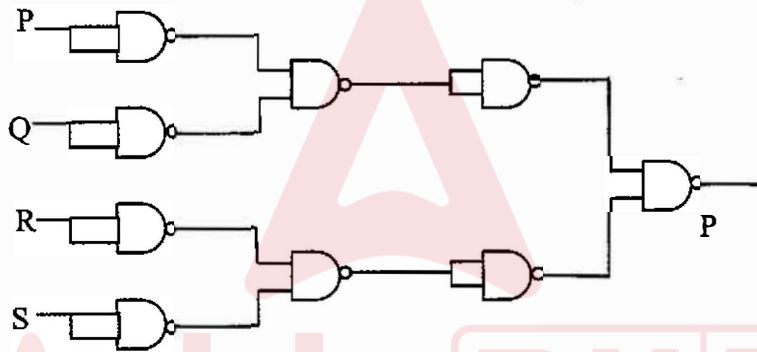

- A) $P' + Q' + R' + S'$ B) $P + Q + R + S$
 C) $(P' + Q')(R' + S')$ D) $(P + Q)(R + S)$

82. Assume that D1 and D2 in figure are ideal diodes. The value of current I is

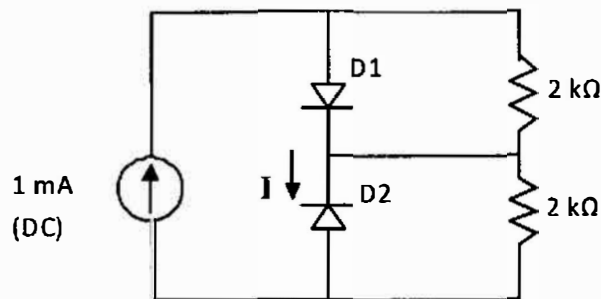

- A) 0 mA B) 0.25 mA C) 0.5 mA D) 1.0 mA

83. Assume that the n-channel MOSFET shown in figure is ideal and that its threshold voltage is +1.0 V. The voltage V_{ab} between nodes a and b is

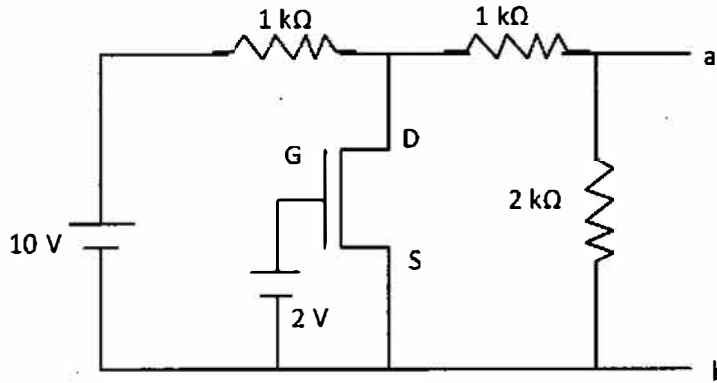

- A) 5 V B) 2 V C) 1 V D) 0V
84. An amplifier without feedback has a gain of 1000. The gain with a negative feedback of 0.009 is
- A) 10 B) 100 C) 125 D) 900
85. If the contents of an accumulator are Ex-ORed with itself and placed in the accumulator itself, then
- A) Carry flag will be set
 B) The accumulator contains all 1's
 C) The zero flag is set
 D) The accumulator contents are shifted left by one bit
86. An operational amplifier has an open loop gain of 200,000. Its output exhibits saturation at 10V. The threshold differential voltage of the amplifier is
- A) 25 micro-volt B) 50 micro-volt
 C) 5 Volts D) 10 volts
87. The number of comparators required in a 3-bit comparator type analog to digital converter is
- A) 2 B) 3 C) 7 D) 8
88. A thyristor (SCR) turns off when the
- A) Gate pulse is removed
 B) Gate pulse is applied
 C) Thyristor current is below holding value
 D) Anode voltage is made negative

95. The number of p-n junctions in a thyristor are
A) 1 B) 2 C) 3 D) 4
96. The function of snubber circuit across a SCR is to
A) Eliminate dv/dt B) Increase dv/dt
C) Reduce dv/dt D) Keep transient over voltage at a constant value
97. In a thyristorised converter a free wheeling diode is used to
A) Add to the conduction current of the thyristor
B) Oppose the thyristor conduction
C) Conduct current during the off period of the thyristor
D) Protect the thyristor by providing a shunt path
98. In d.c. choppers, for periodic time T, the output voltage can be controlled by frequency modulation by varying
A) T, keeping t_{on} constant
B) t_{on} , keeping T constant
C) T, keeping t_{off} constant
D) t_{off} , keeping T constant
99. For speed control of a.c. drive, the preferred method using thyristors is
A) Phase control
B) Integral cycle control
C) Single pulse PWM control
D) Sinusoidal PWM control
100. An inverter converts
A) d.c. voltage to variable d.c. voltage
B) a.c. voltage to d.c. voltage
C) d.c. voltage to a.c. voltage of constant frequency
D) d.c. voltage to a.c. voltage of variable frequency

Test

Prime

By Adda247

Previous Year Papers PDF

PRACTICE MORE, SCORE HIGHER!



Free
25,000+
PDF's

High-Quality | Exam-Wise | Updated Regularly

ATTEMPT AS
MOCK



Turn PDFs into real exam experience.
Analyze. Improve. Succeed.

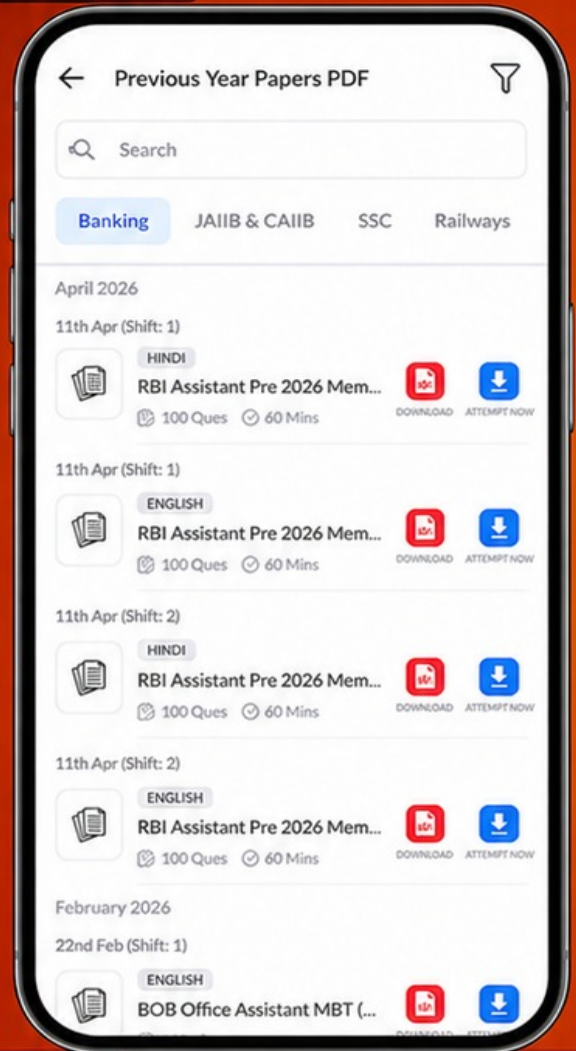

Topic-wise &
Exam-wise PDFs



Download &
Study Offline



Attempt as Mock
& Track Score



Smart Analysis
& Performance

AVAILABLE IN



Banking



SSC



Railway



Teaching



UGC



Agriculture



Nursing



Bihar



UP



Punjab



WB



Odisha



TN



AP & Telangana



Haryana



DOWNLOAD THE APP



| S.No. | Answer | S.No. | Answer | S.No. | Answer | S.No. | Answer |
|-------|--------|-------|--------|-------|--------|-------|--------|
| 1 | C | 26 | C | 51 | A | 76 | A |
| 2 | B | 27 | A | 52 | B | 77 | D |
| 3 | B | 28 | C | 53 | D | 78 | B |
| 4 | D | 29 | D | 54 | C | 79 | D |
| 5 | C | 30 | B | 55 | B | 80 | A |
| 6 | B | 31 | C | 56 | B | 81 | B |
| 7 | B | 32 | C | 57 | B | 82 | A |
| 8 | D | 33 | A | 58 | D | 83 | D |
| 9 | B | 34 | C | 59 | A | 84 | B |
| 10 | D | 35 | D | 60 | C | 85 | C |
| 11 | B | 36 | A | 61 | C | 86 | B |
| 12 | B | 37 | B | 62 | C | 87 | D |
| 13 | A | 38 | A | 63 | D | 88 | C |
| 14 | C | 39 | B | 64 | C | 89 | D |
| 15 | A | 40 | B | 65 | D | 90 | B |
| 16 | A | 41 | D | 66 | B | 91 | C |
| 17 | B | 42 | C | 67 | C | 92 | A |
| 18 | A | 43 | A | 68 | D | 93 | C |
| 19 | B | 44 | A | 69 | D | 94 | D |
| 20 | D | 45 | C | 70 | B | 95 | C |
| 21 | C | 46 | B | 71 | C | 96 | C |
| 22 | A | 47 | A | 72 | C | 97 | C |
| 23 | B | 48 | A | 73 | B | 98 | A |
| 24 | B | 49 | C | 74 | B | 99 | D |
| 25 | C | 50 | C | 75 | B | 100 | D |

| S.No. | Answer | S.No. | Answer | S.No. | Answer | S.No. | Answer |
|-------|--------|-------|--------|-------|--------|-------|--------|
| 1 | B | 26 | A | 51 | B | 76 | A |
| 2 | B | 27 | C | 52 | B | 77 | D |
| 3 | C | 28 | C | 53 | B | 78 | D |
| 4 | C | 29 | A | 54 | A | 79 | C |
| 5 | A | 30 | B | 55 | D | 80 | B |
| 6 | C | 31 | D | 56 | B | 81 | B |
| 7 | D | 32 | C | 57 | D | 82 | D |
| 8 | B | 33 | B | 58 | A | 83 | C |
| 9 | C | 34 | B | 59 | B | 84 | B |
| 10 | C | 35 | B | 60 | A | 85 | B |
| 11 | A | 36 | D | 61 | D | 86 | D |
| 12 | C | 37 | A | 62 | B | 87 | B |
| 13 | D | 38 | C | 63 | C | 88 | D |
| 14 | A | 39 | C | 64 | B | 89 | B |
| 15 | B | 40 | C | 65 | D | 90 | B |
| 16 | A | 41 | D | 66 | C | 91 | A |
| 17 | B | 42 | C | 67 | D | 92 | C |
| 18 | B | 43 | D | 68 | B | 93 | A |
| 19 | D | 44 | B | 69 | C | 94 | A |
| 20 | C | 45 | C | 70 | A | 95 | B |
| 21 | A | 46 | D | 71 | C | 96 | A |
| 22 | A | 47 | D | 72 | D | 97 | B |
| 23 | C | 48 | B | 73 | C | 98 | D |
| 24 | B | 49 | C | 74 | C | 99 | C |
| 25 | A | 50 | C | 75 | C | 100 | A |

| S.No. | Answer | S.No. | Answer | S.No. | Answer | S.No. | Answer |
|-------|--------|-------|--------|-------|--------|-------|--------|
| 1 | C | 26 | B | 51 | D | 76 | C |
| 2 | A | 27 | A | 52 | C | 77 | C |
| 3 | B | 28 | D | 53 | B | 78 | A |
| 4 | D | 29 | B | 54 | B | 79 | C |
| 5 | C | 30 | D | 55 | D | 80 | D |
| 6 | B | 31 | A | 56 | C | 81 | B |
| 7 | B | 32 | B | 57 | B | 82 | C |
| 8 | B | 33 | A | 58 | B | 83 | C |
| 9 | D | 34 | D | 59 | D | 84 | A |
| 10 | A | 35 | B | 60 | B | 85 | C |
| 11 | C | 36 | C | 61 | D | 86 | D |
| 12 | C | 37 | B | 62 | B | 87 | A |
| 13 | C | 38 | D | 63 | B | 88 | B |
| 14 | D | 39 | C | 64 | A | 89 | A |
| 15 | C | 40 | D | 65 | C | 90 | B |
| 16 | D | 41 | B | 66 | A | 91 | B |
| 17 | B | 42 | C | 67 | A | 92 | D |
| 18 | C | 43 | A | 68 | B | 93 | C |
| 19 | D | 44 | C | 69 | A | 94 | A |
| 20 | D | 45 | D | 70 | B | 95 | A |
| 21 | B | 46 | C | 71 | D | 96 | C |
| 22 | C | 47 | C | 72 | C | 97 | B |
| 23 | C | 48 | C | 73 | A | 98 | A |
| 24 | B | 49 | A | 74 | B | 99 | A |
| 25 | B | 50 | D | 75 | B | 100 | C |

| S.No. | Answer | S.No. | Answer | S.No. | Answer | S.No. | Answer |
|-------|--------|-------|--------|-------|--------|-------|--------|
| 1 | B | 26 | D | 51 | C | 76 | C |
| 2 | A | 27 | C | 52 | C | 77 | A |
| 3 | D | 28 | B | 53 | A | 78 | B |
| 4 | B | 29 | B | 54 | C | 79 | D |
| 5 | D | 30 | D | 55 | D | 80 | C |
| 6 | A | 31 | C | 56 | B | 81 | B |
| 7 | B | 32 | B | 57 | C | 82 | B |
| 8 | A | 33 | B | 58 | C | 83 | B |
| 9 | D | 34 | D | 59 | A | 84 | D |
| 10 | B | 35 | B | 60 | C | 85 | A |
| 11 | C | 36 | D | 61 | D | 86 | C |
| 12 | B | 37 | B | 62 | A | 87 | C |
| 13 | D | 38 | B | 63 | B | 88 | C |
| 14 | C | 39 | A | 64 | A | 89 | D |
| 15 | D | 40 | C | 65 | B | 90 | C |
| 16 | B | 41 | A | 66 | B | 91 | D |
| 17 | C | 42 | A | 67 | D | 92 | B |
| 18 | A | 43 | B | 68 | C | 93 | C |
| 19 | C | 44 | A | 69 | A | 94 | D |
| 20 | D | 45 | B | 70 | A | 95 | D |
| 21 | C | 46 | D | 71 | C | 96 | B |
| 22 | C | 47 | C | 72 | B | 97 | C |
| 23 | C | 48 | A | 73 | A | 98 | C |
| 24 | A | 49 | B | 74 | A | 99 | B |
| 25 | D | 50 | B | 75 | C | 100 | B |