



Test Booklet Code & Serial No.

प्रश्नपत्रिका कोड व क्रमांक

A

Paper-II

PHYSICAL SCIENCE

Signature and Name of Invigilator

Seat No.

--	--	--	--	--	--	--	--

(In figures as in Admit Card)

1. (Signature)

(Name)

Seat No.

(In words)

2. (Signature)

(Name)

OMR Sheet No.

--	--	--	--	--	--	--	--

(To be filled by the Candidate)

JUN - 32225

Time Allowed : 2 Hours]

[Maximum Marks : 200

Number of Pages in this Booklet : 32

Number of Questions in this Booklet : 100

Instructions for the Candidates

- Write your Seat No. and OMR Sheet No. in the space provided on the top of this page.
- This paper consists of 100 objective type questions. Each question will carry two marks. All questions of Paper II will be compulsory.
- At the commencement of examination, the question booklet will be given to the student. In the first 5 minutes, you are requested to open the booklet and compulsorily examine it as follows :
 - To have access to the Question Booklet, tear off the paper seal on the edge of this cover page. Do not accept a booklet without sticker-seal or open booklet.
 - Tally the number of pages and number of questions in the booklet with the information printed on the cover page. Faulty booklets due to missing pages/questions or questions repeated or not in serial order or any other discrepancy should not be accepted and correct booklet should be obtained from the invigilator within the period of 5 minutes. Afterwards, neither the Question Booklet will be replaced nor any extra time will be given. The same may please be noted.
 - After this verification is over, the OMR Sheet Number should be entered on this Test Booklet.
- Each question has four alternative responses marked (A), (B), (C) and (D). You have to darken the circle as indicated below on the correct response against each item.
Example : where (B) is the correct response.



Following wrong methods should not be used as they are not recognised by scanning machine in digitized assessment. Candidate using such method will be responsible for their loss.



- Your responses to the items are to be indicated in the OMR Sheet given inside the Booklet only. If you mark at any place other than in the circle in the OMR Sheet, it will not be evaluated.
- Read instructions given inside carefully.
- Rough Work is to be done at the end of this booklet.
- If you write your Name, Seat Number, Phone Number or put any mark on any part of the OMR Sheet, except for the space allotted for the relevant entries, which may disclose your identity, or use abusive language or employ any other unfair means, you will render yourself liable to disqualification.
- You have to return original OMR Sheet to the invigilator at the end of the examination compulsorily and must not carry it with you outside the Examination Hall. You are, however, allowed to carry the Test Booklet and duplicate copy of OMR Sheet on conclusion of examination.
- Use only Blue/Black Ball point pen.
- Use of any calculator or log table, etc., is prohibited.
- There is no negative marking for incorrect answers.

विद्यार्थ्यांसाठी महत्त्वाच्या सूचना

- परीक्षार्थींनी आपला आसन क्रमांक या पृष्ठावरील वरच्या कोपऱ्यात लिहावा. तसेच आपणास दिलेल्या उत्तरपत्रिकेचा क्रमांक त्याखाली लिहावा.
- सदर प्रश्नपत्रिकेत 100 बहुपर्यायी प्रश्न आहेत. प्रत्येक प्रश्नास दोन गुण आहेत. या प्रश्नपत्रिकेतील सर्व प्रश्न सोडविणे अनिवार्य आहे.
- परीक्षा सुरु झाल्यावर विद्यार्थ्यांला प्रश्नपत्रिका दिली जाईल. सुरुवातीच्या 5 मिनिटांमध्ये आपण सदर प्रश्नपत्रिका उघडून खालील बाबी अवश्य तपासून घ्याव्यात.
 - प्रश्नपत्रिका उघडण्यासाठी प्रश्नपत्रिकेवर लावलेले सील उघडावे. सील नसलेली किंवा सील उघडलेली प्रश्नपत्रिका स्वीकारू नये.
 - पहिल्या पृष्ठावर नमूद केल्याप्रमाणे प्रश्नपत्रिकेची एकूण पृष्ठे तसेच प्रश्नपत्रिकेतील एकूण प्रश्नांची संख्या पडताळून घ्यावी. पृष्ठे कमी असलेली/कमी प्रश्न असलेली/प्रश्नांचा चुकीचा क्रम असलेली किंवा इतर त्रुटी असलेली सदोष प्रश्नपत्रिका सुरुवातीच्या 5 मिनिटांतच पर्यवेक्षकांला परत देऊन दुसरी प्रश्नपत्रिका मागवून घ्यावी. त्यानंतर प्रश्नपत्रिका बदलून मिळणार नाही तसेच वेळही वाढवून मिळणार नाही याची कृपया विद्यार्थ्यांनी नोंद घ्यावी.
 - वरीलप्रमाणे सर्व पडताळून पाहिल्यानंतरच प्रश्नपत्रिकेवर ओ.एम.आर. उत्तरपत्रिकेचा नंबर लिहावा.
- प्रत्येक प्रश्नासाठी (A), (B), (C) आणि (D) अशी चार विकल्प उत्तरे दिली आहेत. त्यातील योग्य उत्तराचा रकाना खाली दर्शविल्याप्रमाणे ठळकपणे काढू/निळा करावा.
उदा. : जर (B) हे योग्य उत्तर असेल तर.



खालील चुकीच्या पद्धती वापरू नये, कारण डिजिटाइज्ड (Digitized) मूल्यांकनात स्कॅनिंग मशीन त्यांना ओळखत नाही. त्या पद्धती वापरून नुकसान झाल्यास त्यास विद्यार्थ्यांचा जबाबदार असतील.



- या प्रश्नपत्रिकेतील प्रश्नांची उत्तरे ओ.एम.आर. उत्तरपत्रिकेतच दर्शवावीत. इतर ठिकाणी लिहिलेली उत्तरे तपासली जाणार नाहीत.
- आत दिलेल्या सूचना काळजीपूर्वक वाचाव्यात.
- प्रश्नपत्रिकेच्या शेवटी जोडलेल्या कोऱ्या पानावरच कच्चे काम करावे.
- जर आपण ओ.एम.आर. वर नमूद केलेल्या ठिकाणाव्यतिरिक्त इतर कोठेही नाव, आसन क्रमांक, फोन नंबर किंवा ओळख पटेल अशी कोणतीही खूण केलेली आढळून आल्यास अथवा असभ्य भाषेचा वापर किंवा इतर गैरमागचा अवलंब केल्यास विद्यार्थ्यांला परीक्षेस आपात्र ठरविण्यात येईल.
- परीक्षा संपल्यानंतर विद्यार्थ्यांने मूळ ओ.एम.आर. उत्तरपत्रिका पर्यवेक्षकांकडे परत करणे आवश्यक आहे. तथापि, प्रश्नपत्रिका व ओ.एम.आर. उत्तरपत्रिकेची द्वितीय प्रत आपल्याबरोबर नेण्यास विद्यार्थ्यांना परवानगी आहे.
- फक्त निळा किंवा काळा बॉल पेनचाच वापर करावा.
- कॅल्क्युलेटर किंवा लॉग टेबल वापरण्यास परवानगी नाही.
- चुकीच्या उत्तरासाठी गुण कपात केली जाणार नाही.



**Test
Prime**

By Adda247

ALL EXAMS, ONE SUBSCRIPTION



Test. Analyze. Improve. Repeat.



Don't just *prepare*. Perform.

Test Prime — built only for mock tests.



1,50,000+
Mock Tests



25,000+
Previous Year Papers



800+
Exam Covered



500% Refund
on Selection



5 lakh+
Free Quizzes



Daily
Free PDFs



Job Alerts
Stay Updated

- Multilingual
- Detailed Solution
- Strong and Weak Areas



**All India
Rankings**

Compete with lakhs.
Rank. Improve. Repeat.



← Adda247 test prime

Rating ▾

Editors' choice

New



Adda247 Test Prime
Adda Education • Education
Installed



DOWNLOAD THE APP





JUN - 32225/II—A





JUN - 32225/II—A

Physical Science Paper II

Time Allowed : 120 Minutes]

[Maximum Marks : 200

Note : This paper contains **Hundred (100)** multiple choice questions. Each question carrying **Two (2)** marks. Attempt *All* questions.

- The value of the line integral $I = \int \vec{A} \cdot d\vec{r}$ where $\vec{r} = x\hat{i} + y\hat{j}$ and $\vec{A} = (x+y)\hat{i} + (y-x)\hat{j}$ along the path $y^2 = x$ from the point (1, 1) to the point (4, 2) is :

(A) 10.33 (B) 11.33
(C) 12.33 (D) 13.33
- It is given that the residue of the complex function $\frac{e^{1/z}}{z^n}$ at an isolated singular point $z = 0$ is $\frac{1}{9!}$. The value of n must be equal to :

(A) $n = 1$ (B) $n = -9$
(C) $n = -1$ (D) $n = -8$
- A set V of complex numbers forms a two-dimensional real vector space under the usual addition of complex numbers and multiplication by real numbers. Let $T : V \rightarrow V$ be a linear transformation defined as $T(z) = \bar{z}$. Eigenvalues of T are :

(A) 1, 1 (B) 0, 0
(C) 2, -2 (D) 1, -1
- The function $f(x) = \exp(2x) \sin(2x)$ can be expanded as the Taylor series :

(A) $\sum_{n=0}^{\infty} 2^{\frac{3n}{2}} \sin\left(\frac{n\pi}{4}\right) \frac{x^n}{n!}$ (B) $\sum_{n=0}^{\infty} 2^{\frac{n}{2}} \sin\left(\frac{n\pi}{4}\right) \frac{x^n}{n!}$
(C) $\sum_{n=0}^{\infty} 2^{\frac{3}{2}} \sin\left(\frac{n\pi}{4}\right) \frac{x^n}{n!}$ (D) $\sum_{n=0}^{\infty} 2^n \sin\left(\frac{n\pi}{4}\right) \frac{x^n}{n!}$





JUN - 32225/II—A

5. The Cauchy principal value of the integral $\int_{-\infty}^{\infty} dx \frac{e^{2ix} \sin x}{x}$ is :
- (A) $2\pi i$ (B) πi
 (C) 0 (D) 1
6. The inverse Laplace transform of $\frac{2s^2}{s^4 + 5s^2 + 4}$ is :
- (A) $\frac{4}{3} \sin(2x) - \frac{2}{3} \sin(x), x > 0$ (B) $\frac{2}{3} \sin(2x) - \frac{4}{3} \sin(x), x > 0$
 (C) $\frac{2}{3} \sin(2x) + \frac{4}{3} \sin(x), x > 0$ (D) $\frac{4}{3} \sin(2x) + \frac{2}{3} \sin(x), x > 0$
7. If $\delta(1-x) = \sum_{n=0}^{\infty} \frac{2n+1}{2} P_n(x)$ where $P_n(x)$ are Legendre polynomials and δ is usual Dirac-delta function, then $\delta(1+x)$ can be expressed in terms of $P_n(x)$ as :
- (A) $\sum_{n=0}^{\infty} \frac{-2n+1}{2} P_n(x)$ (B) $\sum_{n=0}^{\infty} (-1)^n \frac{-2n+1}{2} P_n(x)$
 (C) $\sum_{n=0}^{\infty} (-1)^n \frac{2n-1}{2} P_n(x)$ (D) $\sum_{n=0}^{\infty} (-1)^n \frac{2n+1}{2} P_n(x)$
8. Let X be a random variable. Define the random variable $Y = X - \langle X \rangle$. Let $\langle X \rangle = \mu$ and $\langle (X - \mu)^2 \rangle = \sigma^2$. Choose the correct alternative :
- (A) $\langle Y \rangle = \mu$ and $\langle (Y - \langle Y \rangle)^2 \rangle = \sigma^2$ (B) $\langle Y \rangle = 0$ and $\langle (Y - \langle Y \rangle)^2 \rangle = \sigma^2$
 (C) $\langle Y \rangle = 0$ and $\langle (Y - \langle Y \rangle)^2 \rangle = 0$ (D) $\langle Y \rangle = 0$ and $\langle (Y - \langle Y \rangle)^2 \rangle = \sigma^2 - \mu^2$
9. The Wronskian of two solutions of the differential equation,

$$x^4 \frac{d^2 y(x)}{dx^2} - 2x^3 \frac{dy(x)}{dx} - x^8 y(x) = 0$$

is (upto a multiplicative constant) :

- (A) x (B) x^2
 (C) x^3 (D) x^4





JUN - 32225/II—A

14. Consider S' a rotating frame rotating with constant angular velocity ω with respect to stationary reference frame S (S and S' are having a common origin).

If \bar{A} is any vector represented in S' frame, then $\frac{d^2\bar{A}}{dt^2}$ in S frame is given by :

- (A) $\left. \frac{d^2\bar{A}}{dt^2} \right|_{S'} + \left. \frac{d\omega}{dt} \right|_{S'} \times \bar{A} + 2\omega \times \left. \frac{d\bar{A}}{dt} \right|_{S'} + \omega \times \omega \times \bar{A}$ (B) $\left. \frac{d^2\bar{A}}{dt^2} \right|_{S'} + \left. \frac{d\omega}{dt} \right|_{S'} \times \bar{A} + 2\omega \times \left. \frac{d\bar{A}}{dt} \right|_{S'} - \omega \times \omega \times \bar{A}$
 (C) $\left. \frac{d^2\bar{A}}{dt^2} \right|_{S'} + \left. \frac{d\omega}{dt} \right|_{S'} \times \bar{A} - 2\omega \times \left. \frac{d\bar{A}}{dt} \right|_{S'} - \omega \times \omega \times \bar{A}$ (D) $\left. \frac{d^2\bar{A}}{dt^2} \right|_{S'} + \left. \frac{d\omega}{dt} \right|_{S'} \times \bar{A} - 2\omega \times \left. \frac{d\bar{A}}{dt} \right|_{S'} + \omega \times \omega \times \bar{A}$

15. If the potential U in the Lagrangian contains velocity dependent terms, the canonical momentum corresponding to a coordinate of rotation θ of the entire system is no longer the mechanical angular momentum (l_0), but given by

(where $\bar{\nabla}_v$ is the gradient operator in velocity space, \hat{n} is the unit vector along the direction of rotation, l_0^c is the canonical angular momentum)

- (A) $l_0^c = l_0 - \hat{n} \cdot \bar{r} \times \bar{\nabla}_v U$ (B) $l_0^c = l_0 + \hat{n} \cdot \bar{r} \times \bar{\nabla}_v U$
 (C) $l_0^c = l_0 \times \hat{n} \cdot \bar{r} \times \bar{\nabla}_v U$ (D) $l_0^c = l_0 \cdot \hat{n} \cdot \bar{r} \times \bar{\nabla}_v U$

16. A particle initially at rest at point $A(0, 0)$ slides down from a frictionless wire in a vertical plane to another point $B(y_0, z_0)$ under the influence of gravity. Then according to principle of variation, the minimum time (τ) taken by particle can be evaluated using the expression :

(where, $z' = \frac{dz}{dy}$)

- (A) $\frac{1}{\sqrt{2g}} \int_{z=0}^{z_0} \frac{\sqrt{1+z'^2}}{\sqrt{z}} dy$ (B) $\frac{1}{\sqrt{2g}} \int_{z=0}^{z_0} \frac{\sqrt{1-z'^2}}{\sqrt{z}} dy$
 (C) $\frac{1}{\sqrt{2g}} \int_{z=0}^{z_0} \frac{\sqrt{1+z'^2}}{\sqrt{z'}} dy$ (D) $\frac{1}{\sqrt{2g}} \int_{z=0}^{z_0} \frac{\sqrt{1-z'^2}}{\sqrt{zz'}} dy$





JUN - 32225/II—A

17. A number of degrees of freedom for an astronaut constrained to move on surface of a planet (moving freely in space is) :

- (A) 6
- (B) 5
- (C) 4
- (D) 2

18. Let, I_1, I_2, I_3 and $\omega_1, \omega_2, \omega_3$, represent the moment of inertias and angular velocities in the respective principle directions. A rigid body which is symmetric about an a 3rd-axis and has one point fixed on this axis. If A is the component of angular velocity in the direction of the axis of symmetry such that $I_1 = I_2$, then the angular velocity vector $\vec{\omega}$ precesses about the angular momentum vector $\vec{\Omega}$ with a frequency of :

(Given : Euler's equation for the system are

$$\begin{aligned} I_1 \dot{\omega}_1 + (I_3 - I_1) \omega_2 \omega_3 &= 0 \\ I_1 \dot{\omega}_2 + (I_1 - I_3) \omega_3 \omega_1 &= 0 \\ I_3 \dot{\omega}_3 &= 0 \end{aligned}$$

- (A) $\frac{1}{2\pi} \frac{|I_3 - I_1|}{I_1} A$
- (B) $\frac{1}{2\pi} \frac{|I_2 - I_3|}{I_2} A$
- (C) $\frac{1}{2\pi} \frac{|I_1 - I_3|}{I_2} A$
- (D) $\frac{1}{2\pi} \frac{|I_3 + I_1|}{I_1} A$

19. Two masses m_1 and m_2 are attached to the extreme ends of a massless spring of force constant k as shown in figure below. The system is at rest on a horizontal surface. The vibrational frequency w of the system is :

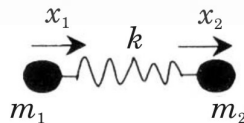

- (A) $\sqrt{\frac{k(m_1 + m_2)}{m_1 m_2}}$
- (B) $\sqrt{\frac{k(m_1 - m_2)}{m_1 m_2}}$
- (C) $\sqrt{\frac{m_1 m_2}{k(m_1 + m_2)}}$
- (D) $\sqrt{\frac{m_1 m_2}{k(m_1 - m_2)}}$





JUN - 32225/II—A

20. A rod AOB (shown in figure below) rotates in a vertical plane [y-z plane] about a horizontal axis about through O perpendicular to this plane [x-axis] with constant angular velocity ω . The equation of motion in \vec{r} for a particle P with mass m and constrain to move along the rod, will be :

(assuming no frictional forces)

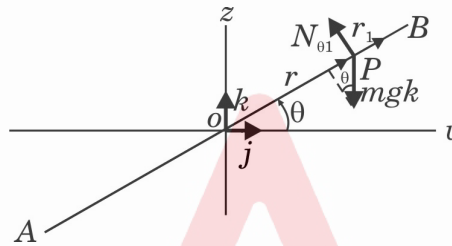

(A) $m \frac{d^2r}{dt^2} - m\omega^2 = -mg \sin(\omega t)$ (B) $m \frac{d^2r}{dt^2} + m\omega^2 = -mg \sin(\omega t)$

(C) $m \frac{d^2r}{dt^2} - m\omega^2 = mg \sin(\omega t)$ (D) $m \frac{d^2r}{dt^2} + m\omega^2 = mg \sin(\omega t)$

21. In a non-relativistic regime, time 't' is considered to be a parameter by changing which we change $q(t), \dot{q}(t)$ and therefore $L(q, \dot{q}, t)$ as a whole. Now we consider 't' (time) to be an independent co-ordinate itself, and θ is the parameter varying

which we vary $q(\theta), q'(\theta) = \frac{dq}{d\theta}, t(\theta)$ and therefore $L_0\left(q(\theta), q'(\theta), t(\theta), t'(\theta) = \frac{dt}{d\theta}, \theta\right)$.

If the action (I) remains invariant under this re-parameterisation, then :

(A) $L_0 = t' L\left(q, \frac{q'}{t'}, t\right)$ (B) $L_0 = L\left(q, \frac{q'}{t'}, t\right)$

(C) $L_0 = \frac{t'}{q'} L\left(q, \frac{q'}{t'}, t\right)$ (D) $L_0 = \frac{q'}{t'} L\left(q, \frac{q'}{t'}, t\right)$





JUN - 32225/II—A

22. The in order to have following transformation to be canonical

$$Q = q^{1/\alpha} \cos(\beta p)$$

$$P = q^{1/\alpha} \sin(\beta p)$$

what should be the value of α and β ?

- (A) $\alpha=1, \beta=1$ (B) $\alpha=\frac{1}{2}, \beta=2$
 (C) $\alpha=2, \beta=\frac{1}{2}$ (D) $\alpha=2, \beta=2$

23. The Hamiltonian of a free particle is $H = \frac{p^2}{2m}$. The phase space will be :

(Where, m, p and E are mass, momentum and energy of the particle, respectively)

- (A) A straight line parallel to q -axis, intersecting the p -axis
 (B) A straight line parallel to p -axis, intersecting the q -axis
 (C) A straight line with slope $\sqrt{2mE}$
 (D) A straight line with slope $-\sqrt{2mE}$
24. Which identity of the following does not hold true for Poisson bracket ?
 (Where all the symbols have their usual meaning)

- (A) $[x_i, p_j] = \delta_{ij}$ (B) $[L_i, L_j] = \delta_{ij}$
 (C) $[L_i, p_j] = \epsilon_{ijk} p_k$ (D) $[x_i, L_j] = \epsilon_{ijk} x_k$

25. A planet moving with a velocity of $0.6 c$, where c is the velocity of light. An astronaut performing an observes a particle moving with a velocity of $0.5 c$ in the same direction as that of the motion of the planet. A stationary observer on the earth would observe the particle to have the velocity

- (A) $0.6 c$ (B) $0.5 c$
 (C) $0.45 c$ (D) $0.27 c$





JUN - 32225/II—A

26. Consider a particle P of mass m moving on XY plane (shown in Fig.). Two forces are acting on the particle. \vec{F}_1 acts towards the origin and \vec{F}_2 acts parallel to x-axis. The classical equation of motion of the particle under these two forces in (r, θ) coordinates will be :

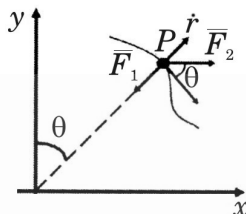

- (A) $m(\ddot{r} - r\dot{\theta}^2) = (F_1 - F_2 \sin \theta)$ and $m(2\dot{r}\dot{\theta} + r\ddot{\theta}) = F_2 \cos \theta$
 (B) $m(\ddot{r} - r\dot{\theta}^2) = (F_1 - F_2 \sin \theta)$ and $m(2\dot{r}\dot{\theta} - r\ddot{\theta}) = F_2 \cos \theta$
 (C) $m(\ddot{r} - r\dot{\theta}^2) = (F_1 + F_2 \sin \theta)$ and $m(2\dot{r}\dot{\theta} - r\ddot{\theta}) = F_2 \sin \theta$
 (D) $m(\ddot{r} - r\dot{\theta}^2) = (F_1 - F_2 \cos \theta)$ and $m(2\dot{r}\dot{\theta} - r\ddot{\theta}) = F_2 \cos \theta$
27. An electric charge distribution produces an electric field, $\vec{E} = E_0(1 - e^{-r/r_0})\frac{\vec{r}}{r^3}$. The net charge within a sphere of radius r_0 centered at the origin is

- (A) $4\pi\epsilon_0 E_0 \left(1 + \frac{1}{e}\right)$ (B) $4\pi\epsilon_0 E_0 \left(1 - \frac{1}{e}\right)$
 (C) $4\pi\epsilon_0 E_0 \left(e + \frac{1}{e}\right)$ (D) $4\pi\epsilon_0 E_0 \left(e - \frac{1}{e}\right)$

28. Two infinite planes, both positively charged, with surface charge density σ each are placed parallel at $x = -a$ and $x = a$ respectively. Which of the following statements is correct ?

- (A) $\vec{E} = \vec{0}$ for $|x| > a$ and $\vec{E} = \frac{\sigma}{\epsilon_0} \hat{x}$ for $|x| < a$
 (B) $\vec{E} = \vec{0}$ for $|x| > a$; $\vec{E} = \frac{\sigma}{\epsilon_0} \hat{x}$ for $0 < x < a$ and $\vec{E} = -\frac{\sigma}{\epsilon_0} \hat{x}$ for $-a < x < 0$
 (C) $\vec{E} = \vec{0}$ for $|x| > a$; $\vec{E} = \frac{\sigma}{\epsilon_0} \hat{x}$ for $-a < x < 0$ and $\vec{E} = -\frac{\sigma}{\epsilon_0} \hat{x}$ for $0 < x < a$
 (D) $\vec{E} = \vec{0}$ for $|x| < a$ and $\vec{E} = \frac{\sigma}{\epsilon_0} \hat{x}$ for $x > a$ and $\vec{E} = -\frac{\sigma}{\epsilon_0} \hat{x}$ for $x < -a$





JUN - 32225/II—A

29. A uniform surface current is flowing in the positive y-direction over an infinite sheet lying in x - y plane. The direction of the magnetic field is

- (A) along \hat{x} for $z > 0$ and along $-\hat{x}$ for $z < 0$
- (B) along \hat{z} for $z > 0$ and along $-\hat{z}$ for $z < 0$
- (C) along $-\hat{x}$ for $z > 0$ and along \hat{x} for $z < 0$
- (D) along $-\hat{z}$ for $z > 0$ and along \hat{z} for $z < 0$

30. The induced surface current density \vec{K} on a conducting sphere, in a uniform

background magnetic field, is $\vec{K} = \left(\frac{3}{2}\right) \frac{(\vec{B} \times \hat{n})}{\mu_0}$. Where \hat{n} is the outward normal

on the surface of the sphere. Now consider a current I flows in a long, straight wire placed along the z -axis. A conducting sphere of radius R is placed at a distance d from the wire ($R \ll d$). The induced surface current density on the sphere is proportional to

- (A) $\frac{I}{R}$
- (B) $\frac{I}{R^2}$
- (C) $\frac{I}{d}$
- (D) $\frac{I}{d^2}$

31. You cannot separate North pole and South pole of a magnet because if you could,.....

(A) it would have violated Maxwell equation, $\vec{\nabla} \cdot \vec{B} = 0$.

(B) it would have violated Maxwell equation, $\vec{\nabla} \times \vec{B} = \mu_0 \left(\vec{J} + \epsilon_0 \frac{\partial \vec{E}}{\partial t} \right)$.

(C) it would have violated charge conservation, $\vec{\nabla} \cdot \vec{J} + \frac{\partial \rho}{\partial t} = 0$.

(D) none of the Maxwell equations or charge conservation would have been violated but it is not possible for different reasons.





JUN - 32225/II—A

32. Which of the following electric field and magnetic field represent a propagating electromagnetic wave ? (\hat{k} is a unit vector in the direction of the propagation).
- (A) $\vec{E} = \vec{E}_0 (\hat{k} \cdot \vec{r} - ct)^2 e^{-(\hat{k} \cdot \vec{r} - ct)^2}$, $\vec{B} = \hat{k} \times \frac{\vec{E}_0}{c} (\hat{k} \cdot \vec{r} - ct)^2 e^{-(\hat{k} \cdot \vec{r} - ct)^2}$
- (B) $\vec{E} = \vec{E}_0 \sin(\hat{k} \cdot \vec{r} - ct)$, $\vec{B} = \vec{0}$
- (C) $\vec{E} = \vec{E}_0 \sin(\hat{k} \cdot \vec{r}) \cos(ct)$, $\vec{B} = \hat{k} \times \frac{\vec{E}_0}{c} \sin(\hat{k} \cdot \vec{r}) \cos(ct)$
- (D) $\vec{E} = (\hat{k} \cdot \vec{r}) e^{-i(\hat{k} \cdot \vec{r} - ct)}$, $\vec{B} = \frac{\vec{E}_0}{c} (\hat{k} \cdot \vec{r}) e^{-i(\hat{k} \cdot \vec{r} - ct)}$
33. For plane monochromatic electromagnetic wave incident from a denser medium onto a rarer medium (refractive indices of the media are n_1 and n_2 respectively), the Brewster's angle and the critical angle are denoted by θ_B and θ_C respectively. Which of the following statements is correct ?
- (A) $\tan \theta_B = \frac{n_1}{n_2}$ (B) $\sin \theta_C = \frac{n_1}{n_2}$
- (C) $\theta_B < \theta_C$ (D) $\theta_B > \theta_C$
34. An oscillating magnetic dipole is formed by making sinusoidal current flow through a circular loop. Consider this dipole as a perfect dipole. If peak value of current flowing is doubled, then time averaged power radiated by this dipole becomes times the initial power.
- (A) 4 (B) $\frac{1}{4}$
- (C) 16 (D) $\frac{1}{16}$
35. Let q and a denote the charge and the acceleration of a moving point charge. Larmor formula states that total power radiated by the point charge is proportional to $q^\alpha a^\beta$, where
- (A) $\alpha=1$ and $\beta=1$ (B) $\alpha=1$ and $\beta=2$
- (C) $\alpha=2$ and $\beta=1$ (D) $\alpha=2$ and $\beta=2$





JUN - 32225/II—A

36. A relativistic particle of charge q and rest mass m_0 moves with velocity $\vec{v} = v_x \hat{x} + v_y \hat{y}$ in a uniform magnetic field, $\vec{B} = B_0 \hat{z}$. The relativistic Larmor radius R (the radius of the circular path the charged particle takes) is given by

(A) $R = \frac{\gamma m_0 \sqrt{(v_x^2 + v_y^2)}}{qB_0}$

(B) $R = \frac{m_0 \sqrt{(v_x^2 + v_y^2)}}{qB_0}$

(C) $R = \frac{m_0 \sqrt{(v_x^2 + v_y^2)}}{\gamma qB_0}$

(D) $R = \frac{\gamma^2 m_0 \sqrt{(v_x^2 + v_y^2)}}{qB_0}$

37. For a localized time varying current distribution, if the Poynting vector, \vec{S} varies as $|\vec{S}| \propto \frac{1}{r^n}$, where r is the distance from the center of the current distribution, then

- (A) $n \leq 2$ because surface integral of Poynting vector has to be non-zero; electromagnetic fields created by this configuration are radiating fields.
- (B) $n > 2$ because the localized time varying current distribution creates a radiating electromagnetic fields.
- (C) $n > 2$ and the electromagnetic fields are not radiating.
- (D) one cannot say anything about n without more information about the current distribution.

38. If in terms of 4-vector potential, all the Maxwell equations can be written as

$$\nabla^2 A^\mu - \frac{1}{c^2} \frac{\partial^2 A^\mu}{\partial t^2} = -\mu_0 J^\mu, \text{ then which of the following statements is true ?}$$

- (A) It is not true because only inhomogeneous Maxwell equations can be written as above.
- (B) In any gauge it is true.
- (C) It is true when Lorentz gauge condition, $\frac{\partial A^\mu}{\partial x^\mu} = 0$ is satisfied.
- (D) It is true under the condition, $\vec{\nabla} \cdot \vec{A} = 0$.





JUN - 32225/II—A

39. Consider a rectangular wave guide with dimensions $2.28 \text{ cm} \times 1.01 \text{ cm}$. What TE modes will propagate, if the driving frequency is 17 GHz ? And, to excite only one TE mode, what range of frequencies could be used ?

- (A) $3.3 \text{ GHz} \leq \nu < 6.6 \text{ GHz}$ (B) $6.6 \text{ GHz} \leq \nu < 13.2 \text{ GHz}$
 (C) $66 \text{ GHz} < \nu \leq 132 \text{ GHz}$ (D) $1.62 \text{ GHz} \leq \nu < 6.6 \text{ GHz}$

40. A one-dimensional box contains three identical particles in the ground state of the system. Find the ratio of the total energies of these particles if they were spin-1/2 fermions, to that if they were bosons.

- (A) 1 (B) $14/3$
 (C) 2 (D) $1/3$

41. The operator $\left(\frac{d}{dx} - x\right)\left(\frac{d}{dx} + x\right)$ is equivalent to :

- (A) $\frac{d^2}{dx^2} - x^2$ (B) $\frac{d^2}{dx^2} - x^2 + 1$
 (C) $\frac{d^2}{dx^2} - x \frac{d}{dx} x^2 + 1$ (D) $\frac{d^2}{dx^2} - 2x \frac{d}{dx} - x^2$

42. The normalized wave function of a particle can be written as

$$\psi(x) = N \sum_{n=0}^{\infty} \left(\frac{1}{\sqrt{7}}\right)^n \phi_n(x)$$

where $\phi_n(x)$ are the normalized energy eigenfunctions of a given Hamiltonian.

The value of N is :

- (A) $\sqrt{\frac{6}{7}}$ (B) $\sqrt{\frac{1}{7}}$
 (C) $\sqrt{\frac{3}{7}}$ (D) $\sqrt{\frac{13}{7}}$

43. Consider a spin-1 particle in the state $|S_z, +1\rangle$. Let P_1^x, P_0^x and P_{-1}^x denote the probabilities that the measurement of S_x gives the values $\hbar, 0$ and $-\hbar$, respectively. Then :

- (A) $P_1^x = 1/2, P_0^x = 1/4, P_{-1}^x = 1/4$ (B) $P_1^x = 1/3, P_0^x = 1/3, P_{-1}^x = 1/3$
 (C) $P_1^x = 1/4, P_0^x = 1/2, P_{-1}^x = 1/4$ (D) $P_1^x = 1/4, P_0^x = 1/4, P_{-1}^x = 1/2$





JUN - 32225/II—A

44. Three mutually non-interacting electrons are confined in a hollow spherical cavity of radius R with impenetrable walls. The average pressure exerted by the electrons on the walls of cavity when the system is in the lowest energy state is given by :

- (A) $\frac{3\pi\hbar^2}{4mR^5}$ (B) $\frac{3\pi\hbar^2}{2mR^5}$
 (C) $\frac{7\pi\hbar^2}{2mR^5}$ (D) $\frac{3\pi\hbar^2}{4mR^3}$

45. Two identical spin-1/2 fermions are placed in a 1-dimensional square potential well with infinitely high walls, $V = 0$ for $0 \leq x \leq L$, otherwise $V = \infty$. The normalized

single particle energy eigenstates are $u_n(x) = \sqrt{\frac{2}{L}} \sin\left(\frac{n\pi x}{L}\right)$; $n = 1, 2, 3, \dots$. Let

s be the quantum number corresponding to total spin \vec{S} . The ground state energy of the system is given by :

- (A) $\frac{5\hbar^2\pi^2}{4mL^2}$ if $s = 1$ (B) $\frac{\hbar^2\pi^2}{mL^2}$ if $s = 1$
 (C) $\frac{\hbar^2\pi^2}{mL^2}$ if $s = 0$ (D) $\frac{5\hbar^2\pi^2}{2mL^2}$ if $s = 0$

46. Consider an isotropic harmonic oscillator in two-dimensions. The Hamiltonian is given by

$$H = \frac{P_x^2}{2m} + \frac{P_y^2}{2m} + \frac{m\omega^2}{2}(x^2 + y^2)$$

A time independent perturbation of the form $H' = \lambda m\omega^2 xy$ (where $\lambda \ll 1$) is introduced in the system. First order energy shift for the ground state is given by :

- (A) $\lambda\hbar\omega$ (B) $\frac{\lambda}{2}\hbar\omega$
 (C) $\frac{\lambda}{4}\hbar\omega$ (D) 0





JUN - 32225/II—A

47. A particle with incoming wave vector \mathbf{k} , after being scattered by the potential $V(r) = \frac{c}{r^2}$, c real, goes out with wave vector \mathbf{k}' . The differential scattering cross-section, calculated in the first Born approximation, depends on $q = |\mathbf{k} - \mathbf{k}'|$, as

- (A) $1/q^2$ (B) $1/q^4$
(C) $1/q$ (D) $1/q^{3/2}$

48. A particle of mass m in three dimensions is subjected to a potential $V(\vec{r}) = A \ln(r/r_0)$ where $r = |\vec{r}|$ and A and r_0 are constants. Then, in some normalized stationary state say $\psi(\vec{r})$, the mean square velocity, $\langle \vec{v}^2 \rangle$, is equal to :

- (A) $2A/m$ (B) $A/2m$
(C) $3A/m$ (D) A/m

49. Consider a spinless particle in a two-dimensional infinite well $V(x, y) = \infty$ for $0 \leq x \leq L, 0 \leq y \leq L$ and $V(x, y) = 0$ otherwise. Add a potential of the form $V'(x, y) = \lambda xy; 0 \leq x \leq L, 0 \leq y \leq L$. Taking this as a weak perturbation, the ground state energy shift at first order is given by :

- (A) $\frac{\lambda L^3}{8}$ (B) $\frac{\lambda L^3}{4}$
(C) $\frac{\lambda L^3}{2}$ (D) λL^3

50. A hydrogen atom is in its ground state : $\psi_{100}(\vec{r}) = \frac{e^{-r/a_0}}{\sqrt{\pi a_0^3}}$. The Coulomb potential

$V(\vec{r}) = -e^2 / r$ of hydrogen atom is perturbed by adding $H' = \lambda x^2$ where λ is a constant parameter. The first order ground state energy shift is :

- (A) $2\lambda a_0^2$ (B) λa_0^2
(C) $\lambda a_0^2 / 2$ (D) $\sqrt{2} \lambda a_0^2$





JUN - 32225/II—A

51. A 1-dimensional Harmonic oscillator of mass m and classical angular frequency ω is described by the Hamiltonian (written in terms of annihilation and creation operators) $H = \hbar\omega(a^\dagger a + 1/2)$. The unperturbed spectra is given by $H|p\rangle = \hbar\omega(p + 1/2)|p\rangle$; $p = 0, 1, 2, \dots$. For $t < 0$ it is in the state $|m\rangle$. At time $t = 0$ the harmonic oscillator potential is perturbed by adding time dependent potential $V(t)$ of the form

$$V(t) = \begin{cases} \lambda(\hbar/2m\omega)^{3/2}[a + a^\dagger]^3, & \text{for } 0 \leq t \leq T \\ 0, & \text{for } t > T \end{cases}$$

Under this the system makes a transition from the state $|m\rangle$ to a state $|n\rangle$. At the first order in perturbation the integer n may be related to m as

[Hint : You may use $\langle n | (a + a^\dagger) | m \rangle = \sqrt{m} \delta_{m,m-1} + \sqrt{m+1} \delta_{n,m+1}$]

- (A) $n = m - 2$ (B) $n = m + 4$
 (C) $n = m + 3$ (D) $n = m - 2$ OR $n = m + 4$
52. The WKB quantization condition for the energy of a particle in a radial potential $V(r)$ with turning points r_1 and r_2 is given by :

(A) $\int_{r_1}^{r_2} dr \sqrt{2m(E_n - V(r))} = (n + 1/2)\pi\hbar$

(B) $\int_{r_1}^{r_2} dr \sqrt{2m \left(E_n - V(r) - \frac{l(l+1)\hbar^2}{2mr^2} \right)} = (n + 1/2)\pi\hbar$

(C) $\int_{r_1}^{r_2} dr \sqrt{2m \left(E_n - V(r) + \frac{l(l+1)\hbar^2}{2mr^2} \right)} = (n + 1/2)\pi\hbar$

(D) $\int_{r_1}^{r_2} dr r^2 \sqrt{2m(E_n - V(r))} = (n + 1/2)\pi\hbar$

53. Two identical random walkers have started walking randomly from the origin on a 1 d lane. They are taking steps simultaneously and of equal length l . They travelled for 10 steps. The probability of meeting together at 4th step is

(A) $\frac{10!}{4!6!} \left[\frac{1}{2} \right]^{10}$

(B) $\left\{ \frac{10!}{4!6!} \left[\frac{1}{2} \right]^{10} \right\}^3$

(C) $\left\{ \frac{10!}{4!6!} \left[\frac{1}{2} \right]^{10} \right\}^2$

(D) $\left\{ \left(\frac{10!}{4!6!} \right)^2 \left[\frac{1}{2} \right]^{10} \right\}^2$





JUN - 32225/II—A

54. The system consists of two indistinguishable particles, each of which can be in either of the two energy states, 0 or ϵ . The system is in thermal equilibrium with a heat bath at temperature T . There is also an interaction energy term that increases the energy by an amount δ if the two particles are in the same energy state. The average energy of the system is $\langle E \rangle = ..$

- (A) $\frac{\delta e^{-\beta\delta} + (2\epsilon + \delta)e^{-\beta(2\epsilon + \delta)} + \epsilon e^{-\beta\epsilon}}{e^{-\beta\delta} + e^{-\beta(2\epsilon + \delta)} + e^{-\beta\epsilon}}$ (B) $\frac{(\delta + \epsilon)e^{-\beta\delta} + (2\epsilon + \delta)e^{-\beta(2\epsilon + \delta)} + \epsilon e^{-\beta\epsilon}}{e^{-\beta\delta} + e^{-\beta(2\epsilon + \delta)} + e^{-\beta\epsilon}}$
- (C) $\frac{\delta + (2\epsilon + \delta) + \epsilon}{e^{-\beta\delta} + e^{-\beta(2\epsilon + \delta)} + e^{-\beta\epsilon}}$ (D) $(2\delta + 3\epsilon) / 3$

55. Due to gravitational force acting on the atmospheric gas particles, atmospheric pressure $P(h)$ decreases with the height h . Consider atmospheric gases behaving like a perfect gas and by balancing the forces acting on a slab of air of thickness dh , the variation in atmospheric pressure as a function of height can be expressed as $P(h) =$

- (A) $29.92 \exp(-mgh/k_B T)$ inch of Hg
 (B) $760 \exp(-\rho gh/k_B T)$ mm of Hg
 (C) $1013 \exp(-mg/k_B T)$ millibars
 (D) $103 \exp(-mgh/k_B T)$ kPa
56. Consider N_a (Avogadro number) number of classical one-dimensional oscillators each having energy given by $E = p^2/2m + 0.5kx^2 + \alpha x^4$ (here k and α are positive constants). The classical specific heat at temperature $T = 400 K$ is $C_v = ..$
- (A) $3R$ (R is gas constant) (B) $2.5 R$
 (C) R (D) $1.25 R$
57. A solid with heat capacity C_A at temperature T_A is placed in contact with the heat bath having P heat capacity C_B at temperature T_B such that $C_B \gg C_A$. The change in entropy of the combined system after a solid reached a thermal equilibrium with a heat bath is $\Delta S =$

- (A) $C_A \ln \frac{T_B}{T_A} + C_B \ln \frac{T_B}{T_A}$ (B) $C_A \left[\ln \frac{T_B}{T_A} + \frac{T_A}{T_B} - 1 \right]$
- (C) $C_A \left[\ln \frac{T_B}{T_A} + \frac{T_B}{T_A} - 1 \right]$ (D) $C_A \ln \frac{T_B}{T_A} + C_B \ln \left(\frac{T_A}{T_B} - 1 \right)$





JUN - 32225/II—A

58. The temperature of an ideal monoatomic gas is changed from T_1 to T_2 , keeping (i) pressure constant, and (ii) keeping its volume constant. Then the ratio of the change in entropy $(\Delta S)_p/(\Delta S)_V$ is :
- (A) 1/2 (B) 1.0
(C) 5/3 (D) 2/3
59. The thermodynamic identity for the ideal rubber band is $dU = Tds + \tau dL$ where T is the temperature, τ is the tension, U is the internal energy of the rubber band, S is its entropy, and L is its length. Which of the following Maxwell's relation is correct for this rubber band system is
- (A) $-\left(\frac{\delta S}{\delta L}\right)_T = \left(\frac{\delta \tau}{\delta T}\right)_L$ (B) $\left(\frac{\delta S}{\delta L}\right)_T = \left(\frac{\delta \tau}{\delta T}\right)_L$
(C) $-\left(\frac{\delta T}{\delta L}\right)_S = \left(\frac{\delta \tau}{\delta S}\right)_L$ (D) $-\left(\frac{\delta S}{\delta \tau}\right)_T = \left(\frac{\delta L}{\delta T}\right)_\tau$
60. The chemical potential μ for an indistinguishable ideal monoatomic gas molecule is $\mu = \dots$ (where, $\beta = 1/(k_B T)$) :
- (A) $-k_B T \left[\ln \frac{V}{N} + \frac{3}{2} \ln \frac{2\pi m}{\beta h^2} + 1 \right]$ (B) $-k_B T \left[\ln \frac{V}{N} + \frac{3}{2} \ln \frac{2\pi m}{\beta h^2} \right]$
(C) $-k_B T \left[\ln \frac{V}{N} + \frac{3}{2} \ln \frac{2\pi m}{\beta h^2} + 5/2 \right]$ (D) $-k_B T \left[\ln V + \frac{3}{2} \ln \frac{2\pi m}{\beta h^2} + 1 \right]$
61. A distant star has its surface temperature of about 2898 K. The wavelengths of light radiation which has maximum intensity emitted from these stars i.e. $\lambda_{\max} =$
- (A) 289.8 nm (B) 1000 nm
(C) 10000 nm (D) 550 nm
62. The ratio of pressure exerted by photon gas to that of the ideal gas particles is to ratio of their energy densities.
- (A) twice (B) thrice
(C) equal (D) half





JUN - 32225/II—A

63. In an ideal Fermi system, if the number density of fermions is decreased to half then the ratio of their single particle momenta corresponding to the Fermi energies is approximately :

- (A) 2.0 (B) 3.2
(C) 0.666 (D) 1.58

64. The external magnetic field B_z is applied to the paramagnetic material containing N number of spin $1/2$ particles each having a magnetic dipole moment μ . The magnetisation $\langle M \rangle$ of a system is measured at low magnetic field and at sufficiently high temperature. Which of the following statements is correct ?

- (A) magnetization $\langle M \rangle = \frac{N\mu^2}{k_B T} B_z$ and susceptibility $\chi \propto T$
 (B) magnetization $\langle M \rangle = \frac{N\mu^2}{k_B T} B_z$ and susceptibility $\chi \propto 1/T$
 (C) magnetization $\langle M \rangle = \frac{N\mu}{k_B T} B_z^2$ and susceptibility $\chi \propto 1/T$
 (D) magnetization $\langle M \rangle = \frac{k_B T}{N\mu^2} B_z$ and susceptibility $\chi \propto T$

65. The density of ideal Bose gas in the condensate state is denoted by $\rho_0(T)$ and ρ be the density of Bose gas in non-condensate state. At the temperature T below a Bose temperature T_b ($T < T_b$) the value of $\rho_0(T) = \dots$

- (A) $\rho \left[1 - \frac{T}{T_b} \right]^{3/2}$ (B) $\rho \left[1 - \frac{T_b}{T} \right]^{3/2}$
 (C) $\rho \left[1 - \frac{T}{T_b} \right]^{1/2}$ (D) $\rho \left(1 - \frac{T}{T_b} \right)$

66. A barrier potential of a P-N junction depends on :

- I. Type of semiconductor
 II. Concentration of doping element
 III. Temperature
 (A) I and II only (B) II only
 (C) II and III only (D) I, II and III





JUN - 32225/II—A

67. The current 'I' supplied by the power supply in the given circuit is

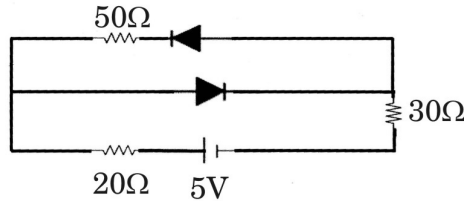

- (A) 1 mA
- (B) 0.05 A
- (C) 0.1 A
- (D) 5 mA

68. From the circuit of the following logic gates the basic logic gate obtained is

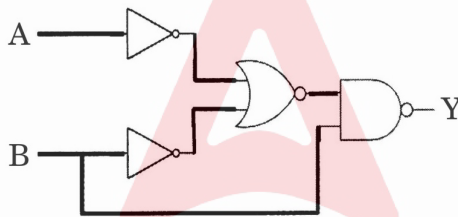

- (A) NOT gate
- (B) AND gate
- (C) OR gate
- (D) NAND gate

69. Find the concentration of holes (p_p) and electronics (n_p) in a type germanium at 300 K, if the conductivity is $100 \Omega \text{ cm}^{-1}$, hole mobility (μ_p) = $1800 \text{ cm}^2/\text{V sec}$, intrinsic charges carrier concentration (n_i) = $2.25 \times 10^{13}/\text{cm}^3$, charge on electron $e = 1.6 \times 10^{-19} \text{ C}$. Assume that the conductivity due to electron is negligible as compared to that due to holes.

- (A) $p_p = 1.83 \times 10^5/\text{cm}^3$, $n_p = 1.83 \times 10^9/\text{cm}^3$
- (B) $p_p = 3.41 \times 10^{17}/\text{cm}^3$, $n_p = 1.83 \times 10^9/\text{cm}^3$
- (C) $p_p = 1.83 \times 10^{19}/\text{cm}^3$, $n_p = 1.83 \times 10^9/\text{cm}^3$
- (D) $p_p = 3.41 \times 10^{17}/\text{cm}^3$, $n_p = 3.41 \times 10^{17}/\text{cm}^3$





JUN - 32225/II—A

70. The co-ordinates of the operating point (Q) for the following JFET circuit are

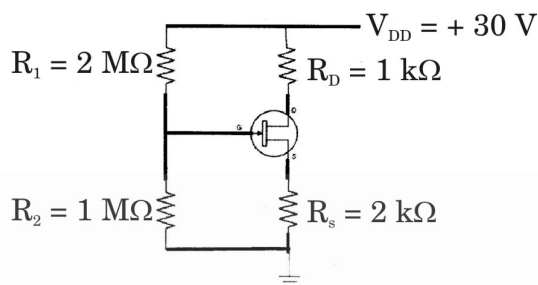

- (A) $V_{DS} = 15 \text{ mV}$, $I_D = 5 \text{ mA}$.
 - (B) $V_{DS} = 5 \text{ mV}$, $I_D = 15 \text{ mA}$.
 - (C) $V_{DS} = 30 \text{ mV}$, $I_D = 10 \text{ mA}$.
 - (D) $V_{DS} = 15 \text{ V}$, $I_D = 5 \text{ mA}$.
71. Consider a 8-bit serial input-parallel output shift registrar operated at clock frequency of 10 MHz. The time taken by the registrar to shift 8 bit number is
- (A) 800 ns
 - (B) 100 ms
 - (C) 100 ns
 - (D) 10 μs
72. Consider R-2R ladder network based on inverting operational amplifier, where D_0 indicates Least Significant Digit (LSB), and D_3 as Most Significant Digit (MSB). If the reference voltage is + 5V, then the output voltage for binary input 1010 is
- (A) - 5.625 V
 - (B) - 6.25 V
 - (C) - 3.125 V
 - (D) 5.0 V





JUN - 32225/II—A

73. A displacement transducer with a shaft stroke of 100 mm is applied to the circuit shown below. The total resistance is $10\text{ k}\Omega$ and voltage is 5 V. If the position of wiper is at a distance of 40 mm from the end A then the value of output voltage $V_0 = \dots\dots\dots$

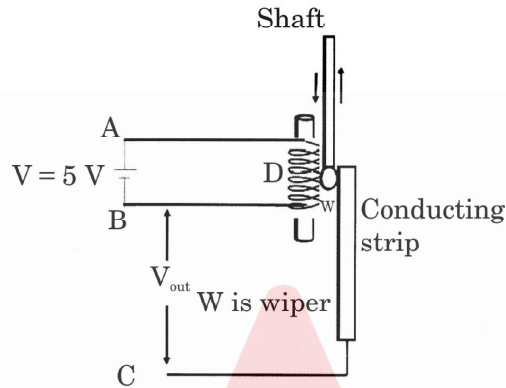

- (A) 3V (B) 2V
 (C) 1.5V (D) 2.5V
74. The output waveform for the following operational amplifier circuit is

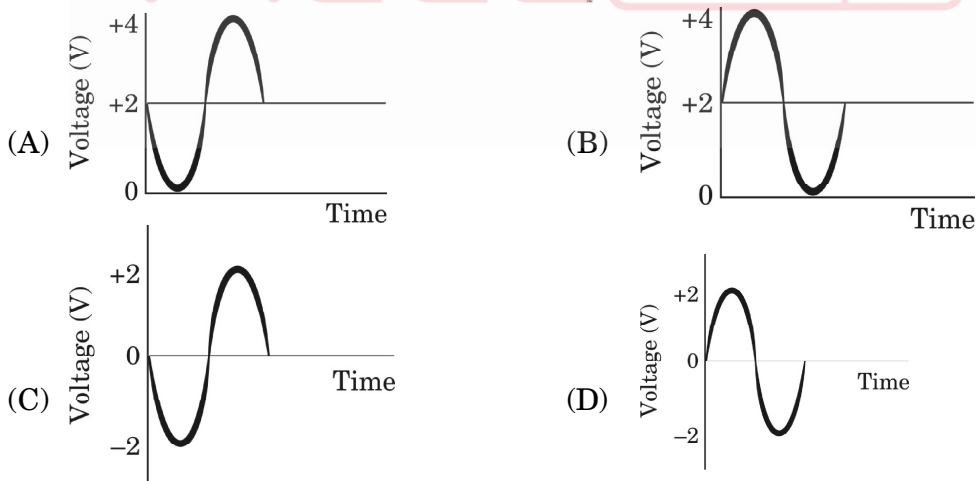
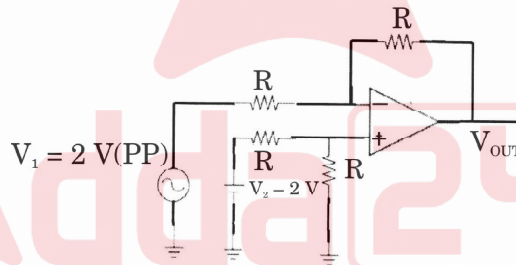



JUN - 32225/II—A

75. For a given full wave bridge rectifier the input line voltage has nominal value of 120V. The actual voltage coming out of the power outlet vary from 105 to 125V and corresponding load voltage as 8.8V and 12.8V respectively. Therefore, the line regulation is

- (A) 4.5%
- (B) 45%
- (C) 22.5%
- (D) 2.25%

76. The output voltage for the following series regulator circuit is

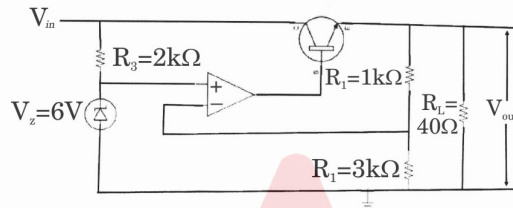

- (A) 7.98V
- (B) 6V
- (C) 3.99V
- (D) 15.96V

77. For a given unijunction transistor (UJT) circuit peak voltage (V_p) is

Diode Voltage $V_D = 0.6V$

Intrinsic stand off ratio (η) = 0.6

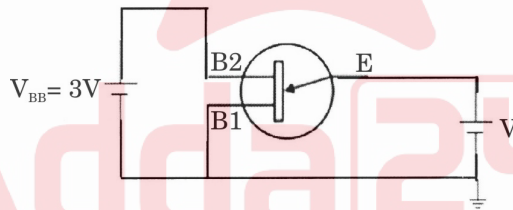

Symbol carrier usual meaning.

- (A) 3.4V
- (B) 1.4V
- (C) 1.0V
- (D) 2.4V

78. In the filtered half wave rectifier circuit as shown below, the value of the DC output voltage is

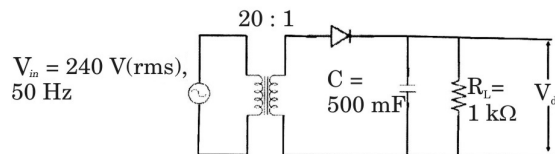

- (A) 12V
- (B) 16V
- (C) 18V
- (D) 17V





JUN - 32225/II—A

79. The fine structure correction to hydrogen atom Bohr energies (including spin-orbit interaction correction and relativistic correction) is given by :

$$\Delta E = \frac{E_n \alpha^2}{n^2} \left(\frac{n}{j + \frac{1}{2}} - \frac{3}{4} \right)$$

where n is the principal quantum number, E_n is the energy of the n th Bohr energy level, α is the fine structure constant, and j is the total angular momentum quantum number. For $n = 2$, the energy corrections ΔE are :

- (A) $0, \frac{3\alpha^2 E_2}{16}$ and $\frac{5\alpha^2 E_2}{16}$ (B) $0, \frac{3\alpha^2 E_2}{16}$ and $\frac{7\alpha^2 E_2}{16}$
 (C) $\frac{5\alpha^2 E_2}{16}$ and $\frac{\alpha^2 E_2}{16}$ (D) 0 and $\frac{7\alpha^2 E_2}{16}$

80. The expression for the weak field Zeeman effect correction E_z to hydrogen atom energies and its values for the ground state energy are (μ_B is the Bohr magneton, g_J the Lande g -factor, m_j the total angular momentum magnetic quantum number, B external magnetic field) :

- (A) $E_z = \mu_B g_J B m_j$, for ground state $E_z = 0$
 (B) $E_z = \mu_B g_J B m_j$, for ground state $E_z = \pm \mu_B B$
 (C) $E_z = \frac{3}{2} \mu_B g_J B m_j$, for ground state $E_z = \pm \frac{3}{2} \mu_B B$
 (D) $E_z = \mu_B g_J B m_j$, for ground state $E_z = \pm \frac{3}{2} \mu_B B$

81. In an electron spin resonance (ESR) experiment, sodium atoms (^{11}Na), in their ground state, are observed to have a resonance frequency $\nu = 1.0 \times 10^{10}$ Hz. Given that for ^{11}Na ground state, Lange g -factor $g_J = 2$ and total angular momentum magnetic quantum number $m_j = \pm 1/2$. What is the external magnetic field applied to obtain the resonance ?

- (Bohr magneton $\mu_B = 9.274 \times 10^{-24}$ J/T, Planck's constant $h = 6.626 \times 10^{-34}$ Js)
 (A) 0.71 Tesla (B) 0.18 Tesla
 (C) 1.2 Tesla (D) 0.36 Tesla





JUN - 32225/II—A

82. An HCl molecule has force constant 516 N/m. Using harmonic oscillator approximation, the vibrational frequency ν and the wave number $\bar{\nu}$ of this molecule are :

(Given : Mass of H atom is 1.674×10^{-27} kg, mass of Cl atom is 5.887×10^{-26} kg, Planck's constant $h = 6.626 \times 10^{-34}$ Js, speed of light $c = 3 \times 10^8$ m/s.)

- (A) $\nu = 89.6 \times 10^{12}$ Hz, $\bar{\nu} = 1890$ cm^{-1}
 (B) $\nu = 179.2 \times 10^{12}$ Hz, $\bar{\nu} = 5974$ cm^{-1}
 (C) $\nu = 89.6 \times 10^{12}$ Hz, $\bar{\nu} = 2987$ cm^{-1}
 (D) $\nu = 44.8 \times 10^{12}$ Hz, $\bar{\nu} = 1493.5$ cm^{-1}

83. For the carbon monoxide (which can be considered a rigid diatomic molecule) for the transition $J = 0$ to $J = 1$ (where J is the rotational quantum number), the wave number $\bar{\nu} = 3.842$ cm^{-1} . The length of CO bond is :

(Given : Mass of carbon atom is 19.921×10^{-27} kg, mass of oxygen atom is 26.561×10^{-27} kg, Planck's constant $h = 6.626 \times 10^{-34}$ Js, speed of light $c = 3 \times 10^8$ m/s.)

- (A) 1.483 Å (B) 0.956 Å
 (C) 1.131 Å (D) 1.762 Å

84. A hypothetical material used was producing a laser beam was consisting of atoms having a three-level system with energies E_1 , E_2 and E_3 such that $E_1 < E_2 < E_3$. The number of atoms in these energy levels were N_1 in E_1 , N_2 in E_2 and N_3 in E_3 , where $N_2 > N_1 > N_3$. Laser emission will be due to transitions between the levels :

- (A) $E_2 \rightarrow E_1$ and $E_1 \rightarrow E_3$ (B) $E_2 \rightarrow E_1$
 (C) $E_1 \rightarrow E_3$ (D) $E_2 \rightarrow E_1$ and $E_3 \rightarrow E_1$





JUN - 32225/II—A

85. In the Born-Oppenheimer approximation for molecular Hamiltonian, the following terms are included (choose the correct alternatives from below) :
- (A) Only kinetic energy of electrons, Coulombic potential energy due to attractions between electrons and nuclei, Coulombic potential energy due to electron-electron repulsions, Coulombic potential energy due to nucleus-nucleus repulsions.
 - (B) Only kinetic energy of nuclei, Coulombic potential energy due to attractions between electrons and nuclei, Coulombic potential energy due to electron-electron repulsions, Coulombic potential energy due to nucleus-nucleus repulsions.
 - (C) Only Coulombic potential energy due to attractions between electrons and nuclei, Coulombic potential energy due to electron-electron repulsions, Coulombic potential energy due to nucleus-nucleus repulsions.
 - (D) Only kinetic energy of nuclei, Coulombic potential energy due to attractions between electrons and nuclei, and Coulombic potential energy due to nucleus-nucleus repulsions.
86. Given a two-dimensional material, in which atoms (denoted by dots) are arranged in a honeycomb lattice with lattice constant a . As shown in the figure, \vec{a}_1 and \vec{a}_2 are two lattice vectors. Which one of the following is the area of the first Brillouin zone for this lattice ?

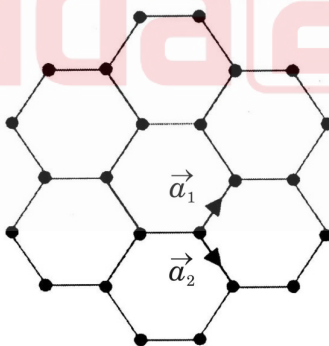

- (A) $\frac{8\pi^2}{\sqrt{3}a^2}$
- (B) $\frac{4\pi^2}{\sqrt{3}a^2}$
- (C) $\frac{8\pi^2}{3\sqrt{3}a^2}$
- (D) $\frac{4\pi^2}{3\sqrt{3}a^2}$





JUN - 32225/II—A

87. A semiconductor with donor impurities can be thought in terms of a filled valence band, a filled donor level and an empty conduction band at $T = 0$, as shown in the figure below.

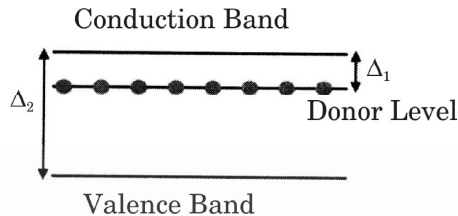

If the band gap between donor level and conduction band is Δ_1 and that between conduction and valence band is Δ_2 where $\Delta_2 \gg \Delta_1$, which of the following figures depict the qualitative features of the resistance (R) vs temperature (T) graph of the semi-conductor? (Assume temperature-independent scattering rates and a flat density of states for the bands.)

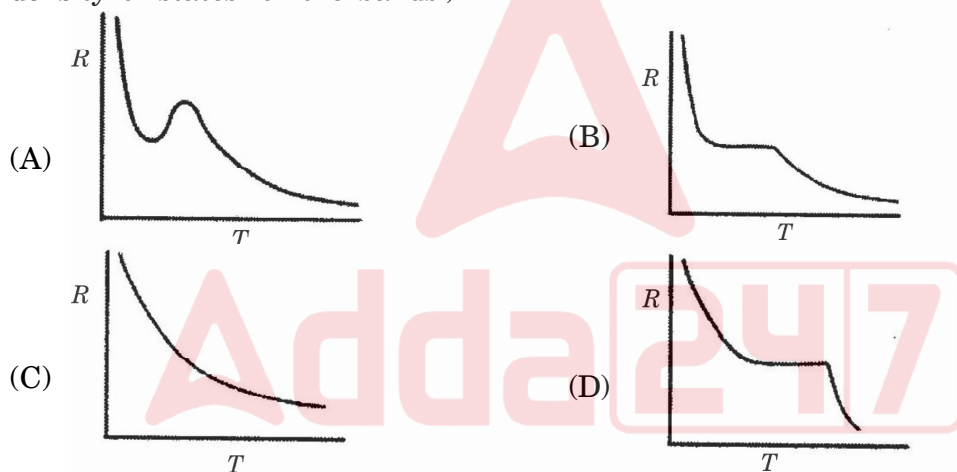

88. Consider a 2-D square lattice of lattice constant a . The ratio of the kinetic energy of a free electron at a corner of the first Brillouin zone (E_c) to that of an electron at the midpoint of a side face of the same zone (E_m) is $E_c/E_m =$

- (A) $1/2$
- (B) 2
- (C) $\sqrt{2}$
- (D) 1

89. Second sound in superfluid helium is :

- (A) the wave motion of entropy and temperature
- (B) the pressure wave
- (C) the density wave
- (D) wave motion of the normal liquid helium





JUN - 32225/II—A

90. Frenkel defect is a defect in solid where :
- oppositely charged ions leave their lattice sites creating vacancy defects
 - dislocations are created
 - disclinations are created
 - smaller ion is displaced from its lattice position to an interstitial site creating vacancy defect and interstitial defect
91. Which of the following statement is true ?
- Quasi crystals are a phase of matter with long range order having symmetry elements forbidden to periodic crystals
 - The liquid-crystalline state has more order than the three-dimensional structure of the solid state
 - Orientalional order refers to translational and rotational symmetry of liquid-crystalline state
 - A liquid-crystalline pattern can continuously fill all available space, but it lacks translational symmetry
92. X-rays of wavelength λ , when incident on the (101) plane of a cubic lattice with lattice constant a produce a first-order Bragg's reflection at $\theta = 30^\circ$ (θ is measured from the lattice plane). Suppose this cubic lattice is compressed along the z-axis such that its lattice parameters along the x- and y-axis remain the same while that along the z-axis becomes $\frac{1}{\sqrt{3}}a$ (see figure).

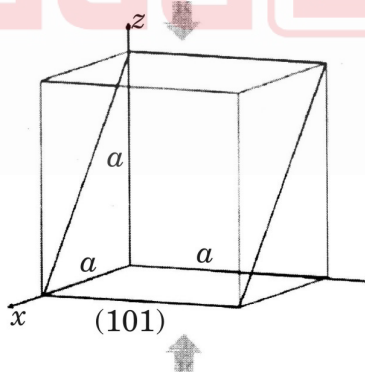

The first-order reflection for the (101) plane of the compressed lattice occurs at :

- $\theta = 45^\circ$
- $\theta = 15^\circ$
- $\theta = 30^\circ$
- $\theta = 60^\circ$





JUN - 32225/II—A

93. The ratio $\frac{\delta(^{15}_7\text{N})}{\delta(^{256}_{100}\text{Fm})}$, where δ denotes the pairing term in the Semi-empirical mass formula (Weizsäcker formula) for binding energy, is :

- (A) -8 (B) 8
(C) -4 (D) 0

94. The Q value of $^{197}_{79}\text{Au} + ^{12}_6\text{C} \rightarrow ^{206}_{85}\text{At} + ?$ in MeV is :

(Given : $1 \text{ u} = 931.5 \text{ MeV}/c^2$, $M(^1_1\text{H}) = 1.007825 \text{ u}$, $M_n = 1.008665 \text{ u}$, $M(^{12}_6\text{C}) = 12.000000 \text{ u}$, $M(^{197}_{79}\text{Au}) = 196.966543 \text{ u}$, $M(^{206}_{85}\text{At}) = 205.986667 \text{ u}$)

- (A) -30 (B) 30
(C) -43 (D) 43

95. A radioactive source with half-life ($\tau_{1/2}$) of 69.3 sec has an activity of $1\mu\text{Ci}$. How many radioactive nuclei will remain after time $t = 69.3 \text{ sec}$?

- (A) 3.7×10^6 (B) 3.7×10^5
(C) 1.85×10^6 (D) 1.85×10^5

96. An alpha particle with an energy of 6.17 MeV is emitted from a natural radioactive source $^{251}_{98}\text{Cf}$ through a process of quantum mechanical tunnelling process. This process is classically forbidden. Estimate the classical barrier range through which the alpha particle escape through a tunnelling process

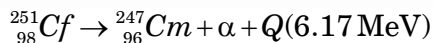

(Given : $R_0 = 1.2 \text{ fm}$ where, R_0 is constant of proportionality in a relation of radius of a nuclei and mass number A)

- (A) 35 fm (B) 8 fm
(C) 45 fm (D) 60 fm





JUN - 32225/II—A

97. According to the scattering experiments of electrons from various nuclei, the nuclear charge density ρ_{ch} as a function of radial distance r is approximated by relation

(Where ρ_0 is constant nucleon density in the core, a is the diffusiveness parameter and R is the average radius of particular nucleus.)

(A) $\rho_{ch}(r) = \frac{\rho_0}{1 + \exp\left(\frac{r-R}{a}\right)}$

(B) $\rho_{ch}(r) = \frac{\rho_0}{1 - \exp\left(\frac{r+R}{a}\right)}$

(C) $\rho_{ch}(r) = \frac{\rho_0}{1 + \exp\left(\frac{r+R}{a}\right)}$

(D) $\rho_{ch}(r) = \frac{\rho_0}{1 - \exp\left(\frac{r-R}{a}\right)}$

98. The only di-nucleon $n-p$ bound system is observed in nature, but not the $n-n$ or $p-p$ di-nucleon bound system, this is because :

- (A) Nuclear forces are mainly central
- (B) Nuclear forces are strongly spin-dependent
- (C) Nuclear forces are charge independent
- (D) Nuclear forces are charge dependent

99. In a particular decay process ${}^{41}_{20}\text{Ca}$ converts to ${}^{41}_{19}\text{K}$, via beta-decay process. From the given information, conclude which type of decay mode is energetically possible :

[Given : $M({}^{41}_{20}\text{Ca}) = 40.962278 \text{ u}$, $M({}^{41}_{19}\text{K}) = 40.961825 \text{ u}$, $M({}^1_1\text{H}) = 1.007825 \text{ u}$, $M_n = 1.008665 \text{ u}$, $M_e = 0.00055 \text{ u}$ and $1 \text{ u} = 931.5 \text{ MeV}/c^2$]

- (A) β^+ decay
- (B) β^- decay
- (C) Electron capture
- (D) Both β^+ and β^- decay

100. For the given reaction, $n + \bar{p} \rightarrow \pi^- + \pi^0$ which of the conservation statement is true ?

- (A) Baryon number (B) is not conserved, the reaction is forbidden
- (B) Electron lepton number (L_e) is not conserved, the reaction is forbidden
- (C) Charge (Q) is not conserved, the reaction is forbidden
- (D) All conservations hold true, the reaction is allowed



Test

Prime

By Adda247

Previous Year Papers PDF

PRACTICE MORE, SCORE HIGHER!



Free
25,000+
PDF's

High-Quality | Exam-Wise | Updated Regularly

ATTEMPT AS
MOCK



Turn PDFs into real exam experience.
Analyze. Improve. Succeed.



Topic-wise & Exam-wise PDFs



Download & Study Offline



Attempt as Mock & Track Score



Smart Analysis & Performance

AVAILABLE IN



Banking



SSC



Railway



Teaching



UGC



Agriculture



Nursing



Bihar



UP



Punjab



WB



Odisha



TN



AP & Telangana



Haryana



DOWNLOAD THE APP





JUN - 32225/II—A

ROUGH WORK

